

PATTERN MAGIC

Tomoko Nakamichi

Now in
English

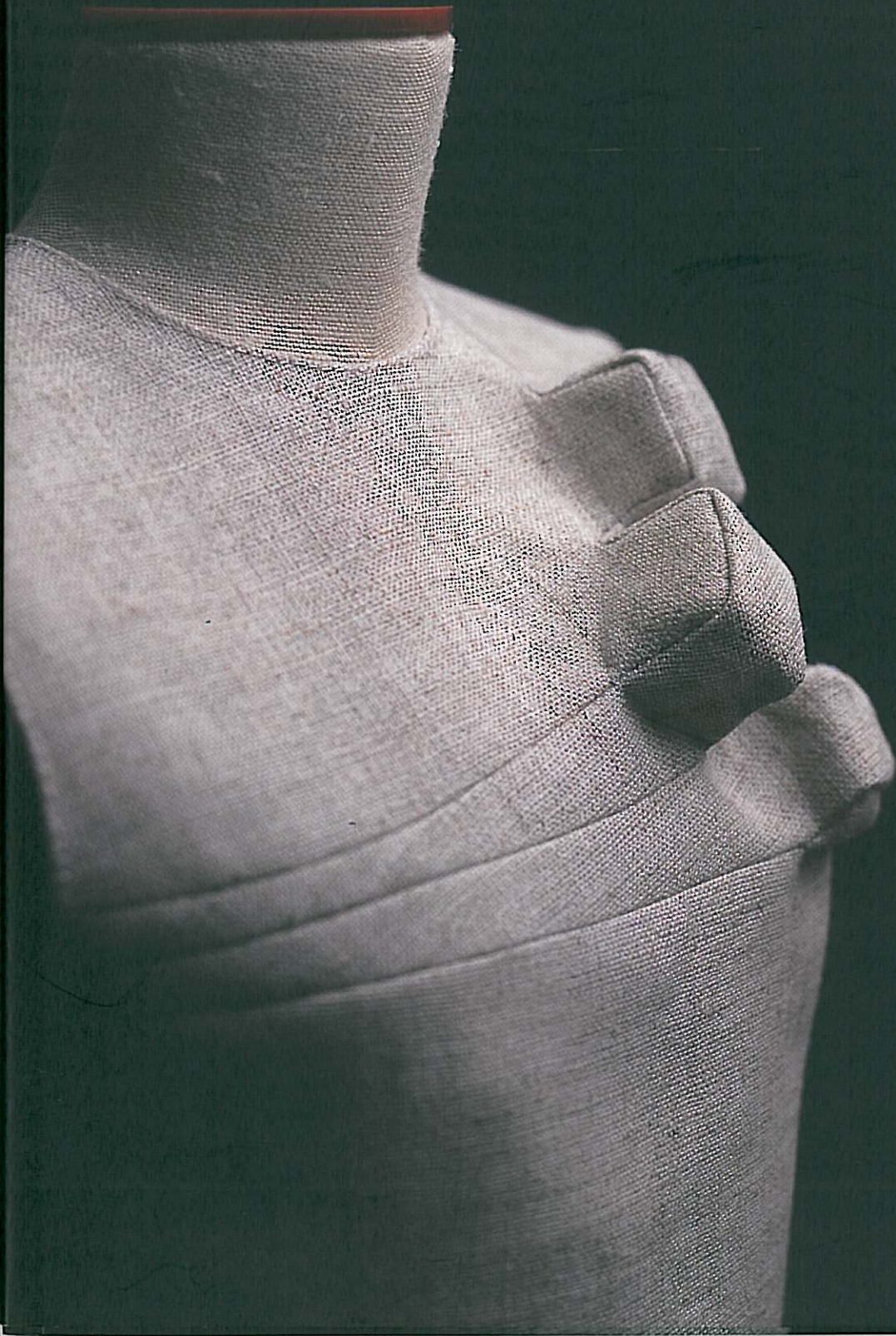

Using this book

At the beginning of this book (page 7) I explained about the relationship between the three-dimensional structure of a garment and flat pattern pieces. A major objective when making garments for women is not only that they fit properly but that they also look attractive. For this reason, garment design will never cease to exist and provide endless enjoyment. I hope the pattern-making method I introduce here is of use to you in turning an image into a silhouette or design detail, and that you learn from the ideas in this book and find new methods that work for you.

The pattern drafting and manipulation for the design of garments in this book are based on the Bunka-style sloper (block) for adult women (Japanese 'M' size: bust 83cm, waist 64cm, centre back length 38cm), and a half-scale dress form for the three-dimensional pattern manipulation. All the measurements on this dress form are half that of a full-sized dress form, its surface area is scaled down to a quarter and its volume to one-eighth. Using a half-scale dress form helps to understand the overall balance and look of a garment. As my objective was to explain the construction of a pattern in an easy-to-follow way, I have omitted pattern markings such as facing lines used for actually constructing the garment and the amount of fabric required to make the garment.

Abbreviations used in pattern drafting

BP
Bust Point

AH
Arm Hole

FAH
Front Arm Hole

BAH
Back Arm Hole

B
Bust

W
Waist

MH
Mid Hip

H
Hip

BL
Bust Line

WL
Waist Line









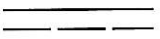

HL
Hip Line

EL
Elbow Line

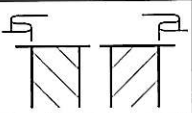
CF
Centre Front

CB
Centre Back

Symbols used in pattern drafting

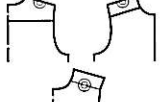
Guide line		Line that acts as a guide when drawing other lines. Shown by a thin solid line.
Sector line		Line indicating that one line of a fixed length has been divided into equal lengths. Shown by a thin broken line.
Finishing line		Line indicating the finished outline of a pattern. Shown by a thick solid line or a broken line.
Cut on the fold		Line indicating where the fabric is to be cut on the fold. Shown by a thick broken line.
Right angle marking		Indicates a right angle. Shown by a thin solid line.
One-way pleats		Draw two diagonal lines sloping downwards towards the hem. Shows that the higher line folds over the lower line.
Grain line		Indicates that the cross-wise grain of the fabric runs in the direction of the arrow. Shown by a thick solid line.
Bias direction		Indicates the direction of the bias of the fabric. Shown by a thick solid line.
Extension marking		Indicates the part to be stretched.
Ease marking		Indicates the part to be eased.
Close and cut open marking		Indicates that the paper pattern is to be folded along the dotted lines and cut open along the solid line.
Marking to cut fabric with paper pattern pieces arranged contiguously		Indicates that the paper pattern pieces are to be arranged contiguously when cutting out the fabric.

Basic bodice pattern

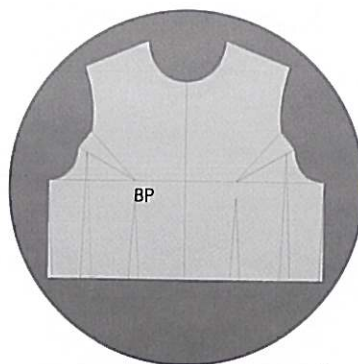

Bodice front pattern based on the Bunka-style sloper (block) (see pages 99–102).



Bodice pattern with closed darts.

Inserting a circular design line

A When the edge of the circle passes through the bust points

Cutting out the circle produces a pattern with the same silhouette as the sloper above.

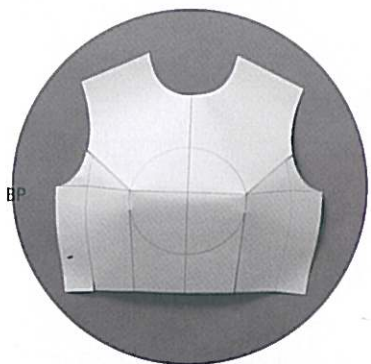

The edge of the circle passes through the bust points.

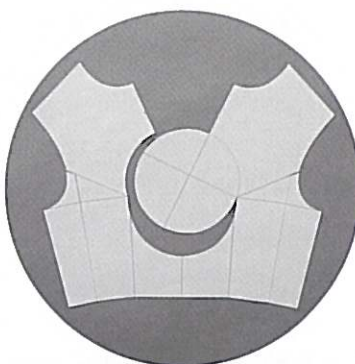

The circle that has been cut out forms the pattern for the design line.

B When the circle extends beyond the bust points

Even if you cut out the circle, the underside does not lie flat and cannot be used as a pattern.



The circle extends beyond the bust points.

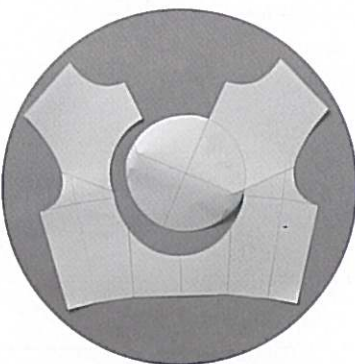

Even if you cut out the circle, it does not lie flat.

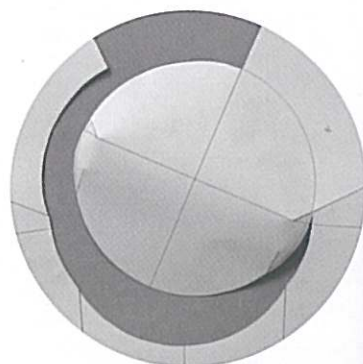

To make a pattern for the circle

Shortening the darts so that they end at the edge of the circle will make the circle lie flat so that a pattern can be made. However, the silhouette will be not be same as the sloper (block).

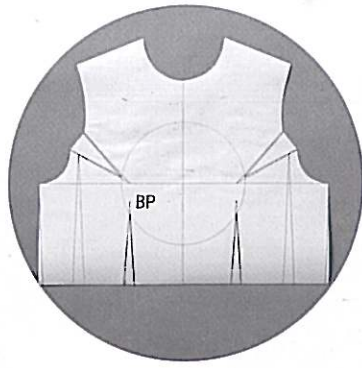

Shorten the darts to end at the edge of the circle.

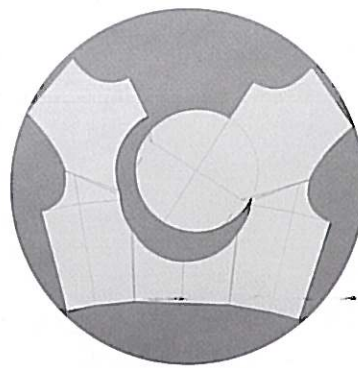

Close the darts and cut out the circle.

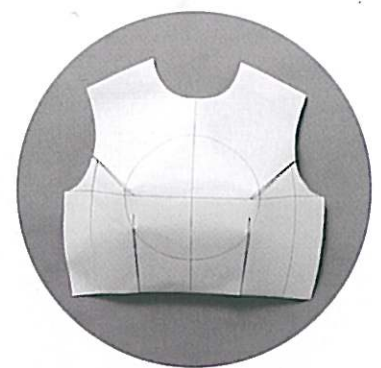

The pattern is not fitted in the chest area and the silhouette is not the same.

Three methods for making a pattern with the same silhouette

They all involve manipulating the darts that are left inside the circle.

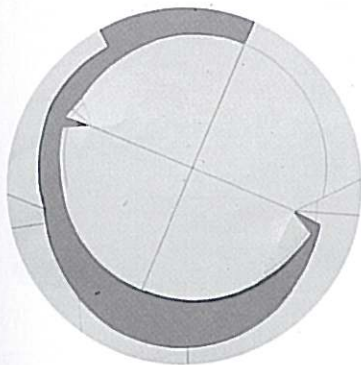

1. Insert darts (Close two darts to make into one).

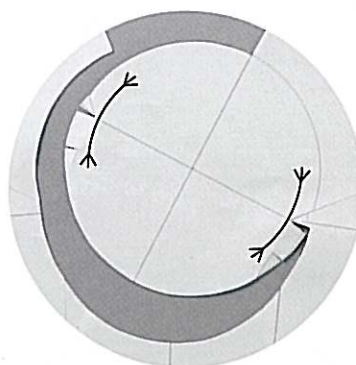

2. Ease.

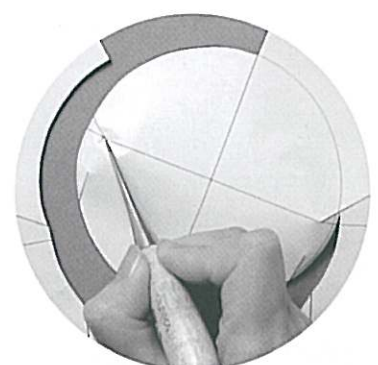

3. Flatten.

"Flatten" means to press down on any fullness that refuses to lie flat. In a similar way to a sugar cube where the corners have been worn away, gentle curves form on the pattern as shown in the drawing. Flattening just a small amount of fullness creates a well-fitted form.

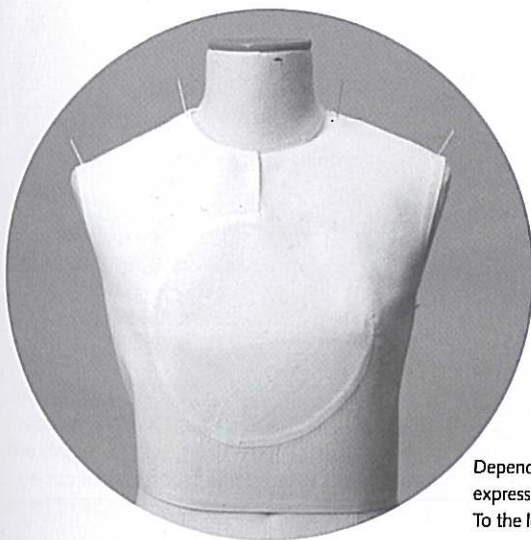
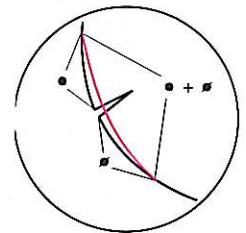

Depending on the method you use, the three-dimensional expression changes from soft to sharp. To the left is a bodice pattern where the darts have been flattened.

Inserting complex design lines into a sloper (block) as a further application of this technique

In the same way as for the bodice with the circular design line, make the bodice pattern out of paper. Draw any kind of line you want and don't forget to insert the position of the opening.

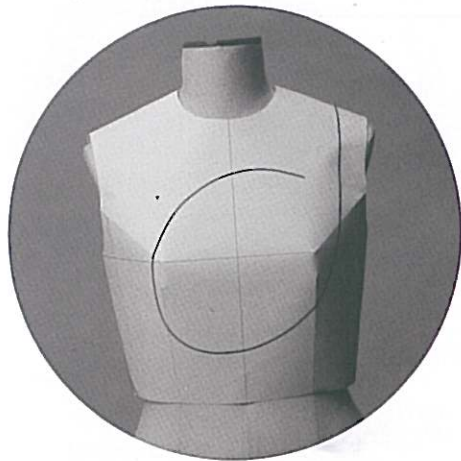

FRONT

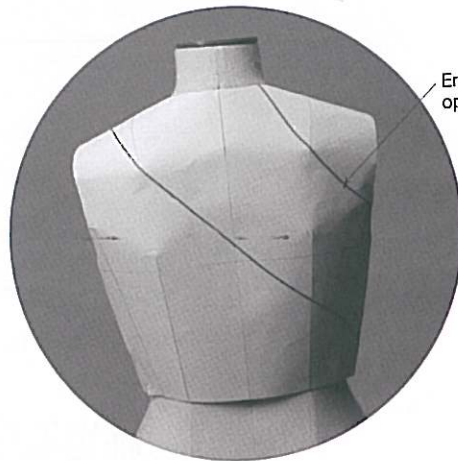

BACK

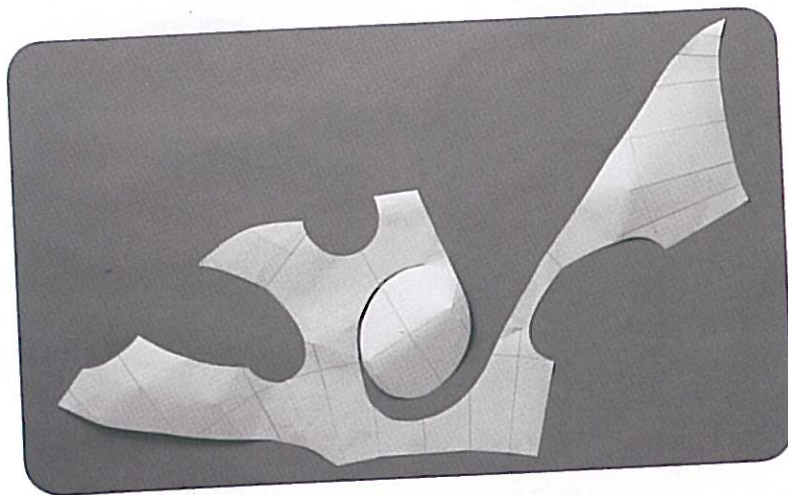

Cut and open out along the lines.

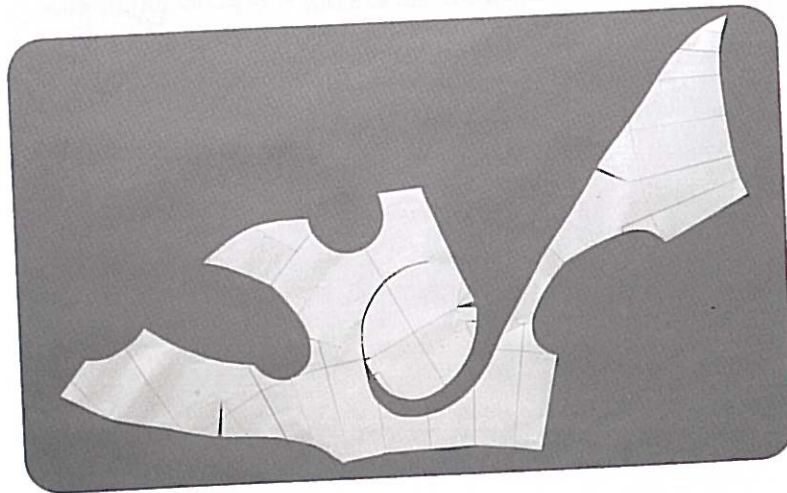

Flatten out the areas that do not lie flat either by inserting darts, easing, or flattening, or by combining these methods.

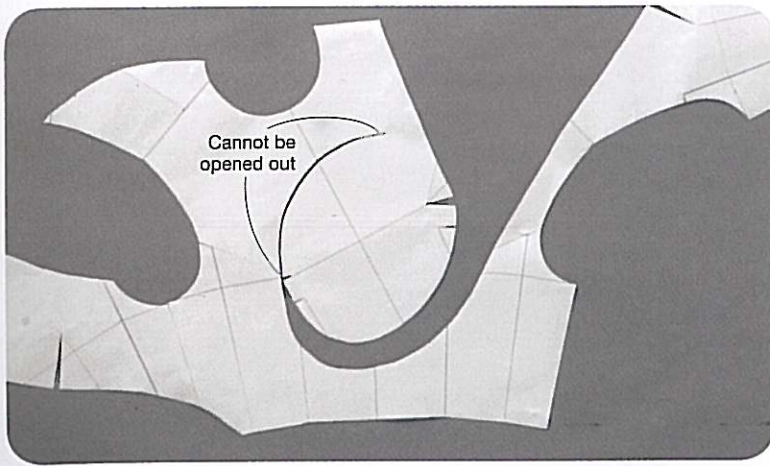

The pattern is flat but the beginning of the curve cannot be opened out because there is no seam allowance for the design line seam.

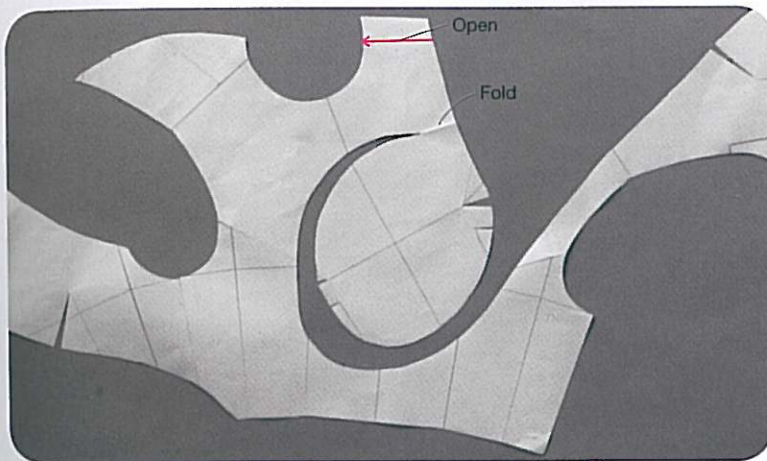

Fold over a small portion at the end of the curve to create some seam allowance. Then, either stretch out the folded portion or cut and open near the shoulder.

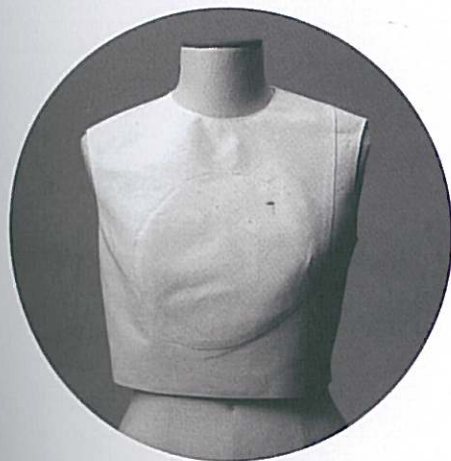

FRONT

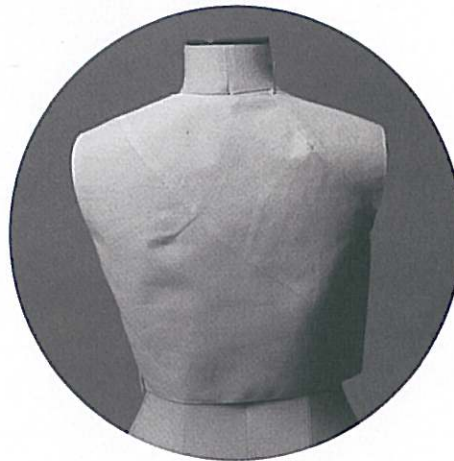

BACK

Although we have to be meticulous about measurements for a garment pattern, in some cases where only a few millimetres are involved, there is nothing wrong with being flexible. Here I have folded and created the seam allowance but you may change the design so that the design lines end at the points up to where you can sew. The fabric also stretches a lot with patterns that have curved design lines, and when you actually cut the fabric out, you will need to adjust the measurements. Select a method considering the overall balance of the garment.

es.

o not lie flat either
r flattening,
hods.

PATTERN MAGIC

Making a pattern

As three-dimensional cutting requires a significant level of skill, the method I adopted here uses a half-scale dress form. This makes it easier to understand the overall shape, and to create patterns based on the silhouette of the sloper (block). Making a pattern is as fascinating as trying to solve a puzzle.



Accents (*deppari*)

This *deppari* protrudes from the back like a shell.
 Since it utilises the unevenness of the body,
 it doesn't just have to be the back
 from which a *deppari* protrudes.
 They can be positioned anywhere, on the back
 or on the chest, to create a sharp design line.
 Here are two interesting *deppari* designs.

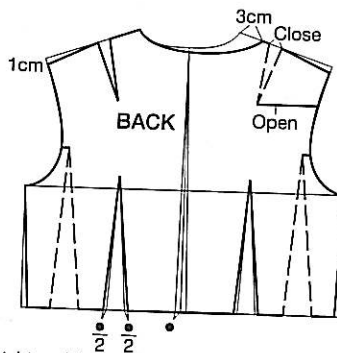
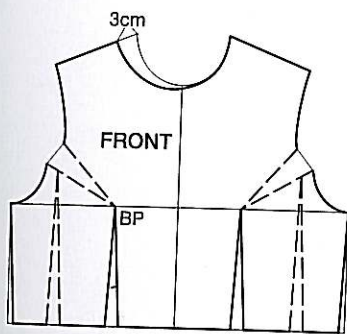
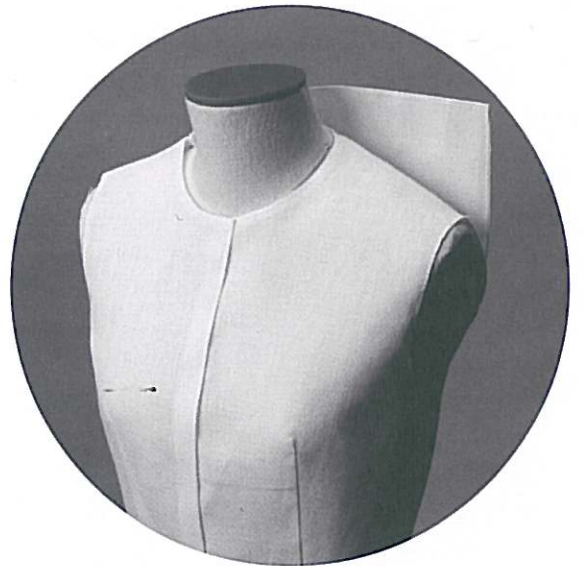

① Because the *deppari* comes into contact with the right neckline, make only the right bodice back neckline significantly deeper.

② To make the *deppari* appear to be protruding from the curve of the shoulder blade ends, draw it from the end of the shoulder dart on the pattern. To make the *deppari* neat, move the right shoulder dart to the AH.

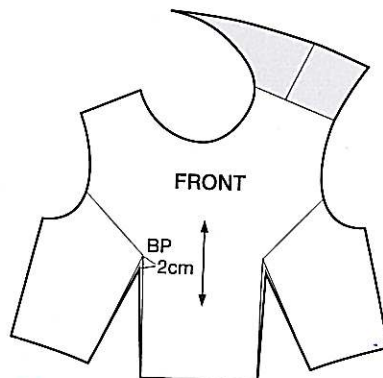
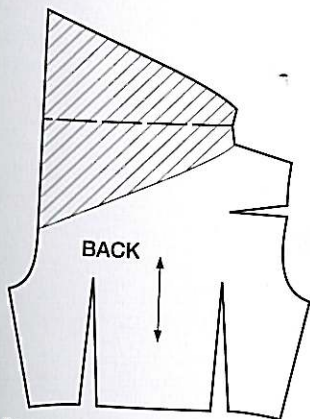

③ Reverse the *deppari* again and cut out.

④ As the projection will be neater if there is no shoulder seam, close the left shoulder dart and cut this section continuously with the bodice front.

Page 13: Deppari shirt

The *deppari* on the chest utilises the fullness of the bust. The sharp accent in the chest area of the crisp high-quality cotton shirt has a coolness that is reminiscent of a safari-style shirt.

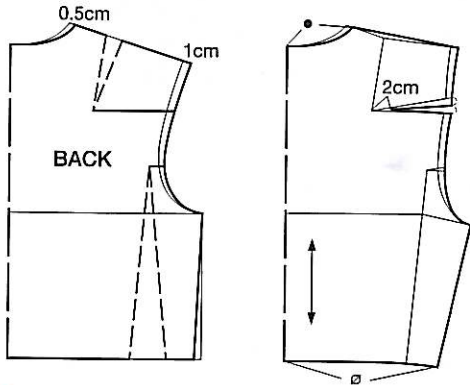

1 Because the shirt does not have to be particularly fitted to the body, divide the shoulder dart allowance that was moved to the AH into two equal sections. Distribute one half into the darts, and the rest in the armhole. Shorten the dart because the dart allowance is small.

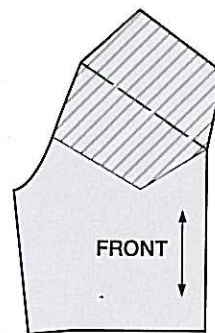
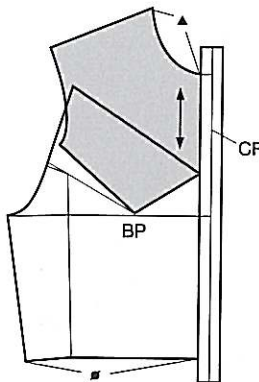
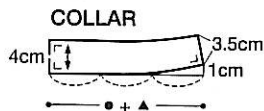
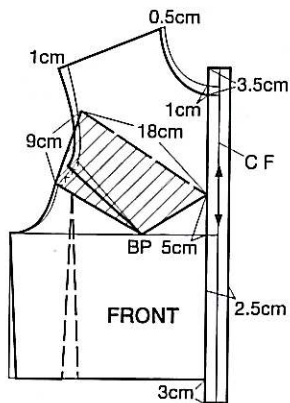
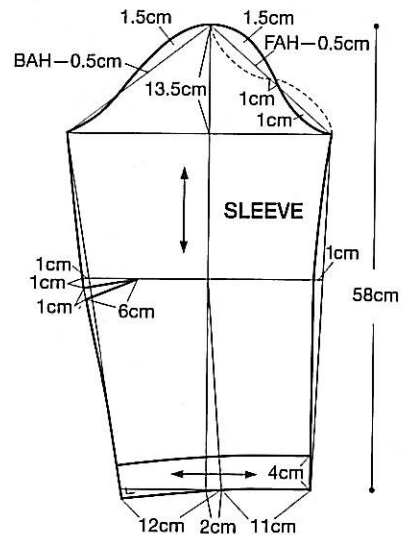

2 Draw the *deppari*. Divide the bust dart allowance into three equal sections, distribute one third into ease in the armhole, leave two thirds for the bust dart and sew the *deppari* to the armhole.

3 Reverse the *deppari* and cut out.



Gathered hole

An interesting look where a hole is opened and gathered without changing the silhouette of the garment.

The gathers are arranged at a right angle to the seam, forming a radial pattern around the hole (or circle).

The design for this pattern is based on this principle.



Page 14: Dress with gathered hole

A design where a hole is opened and gathered in a fitted silhouette, without inserting darts or design lines.

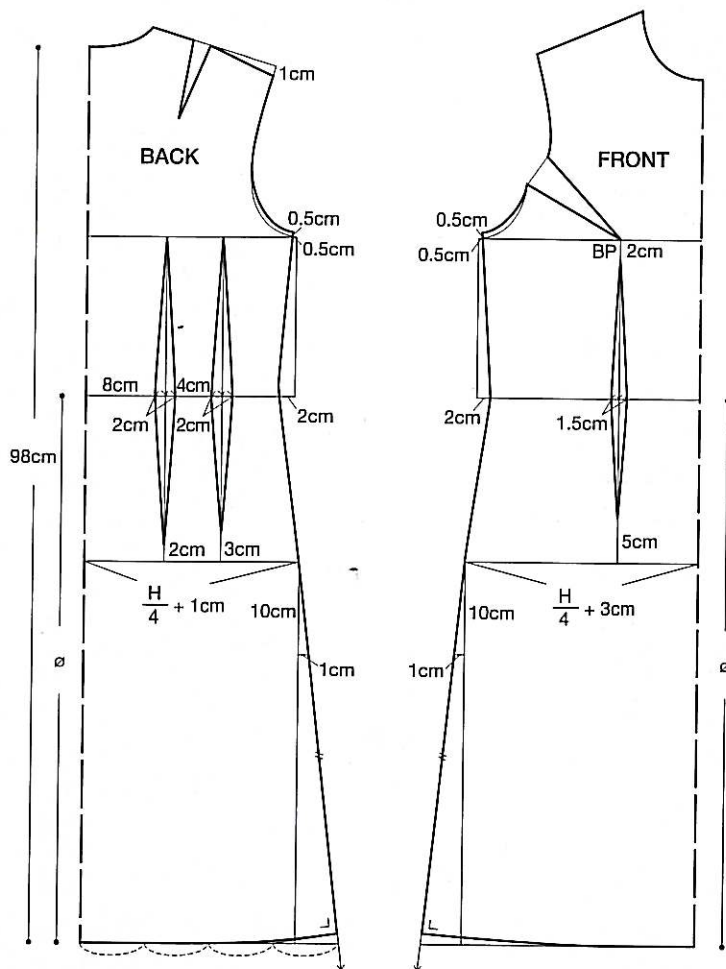

① Draft a pattern of a dress with a fitted silhouette.

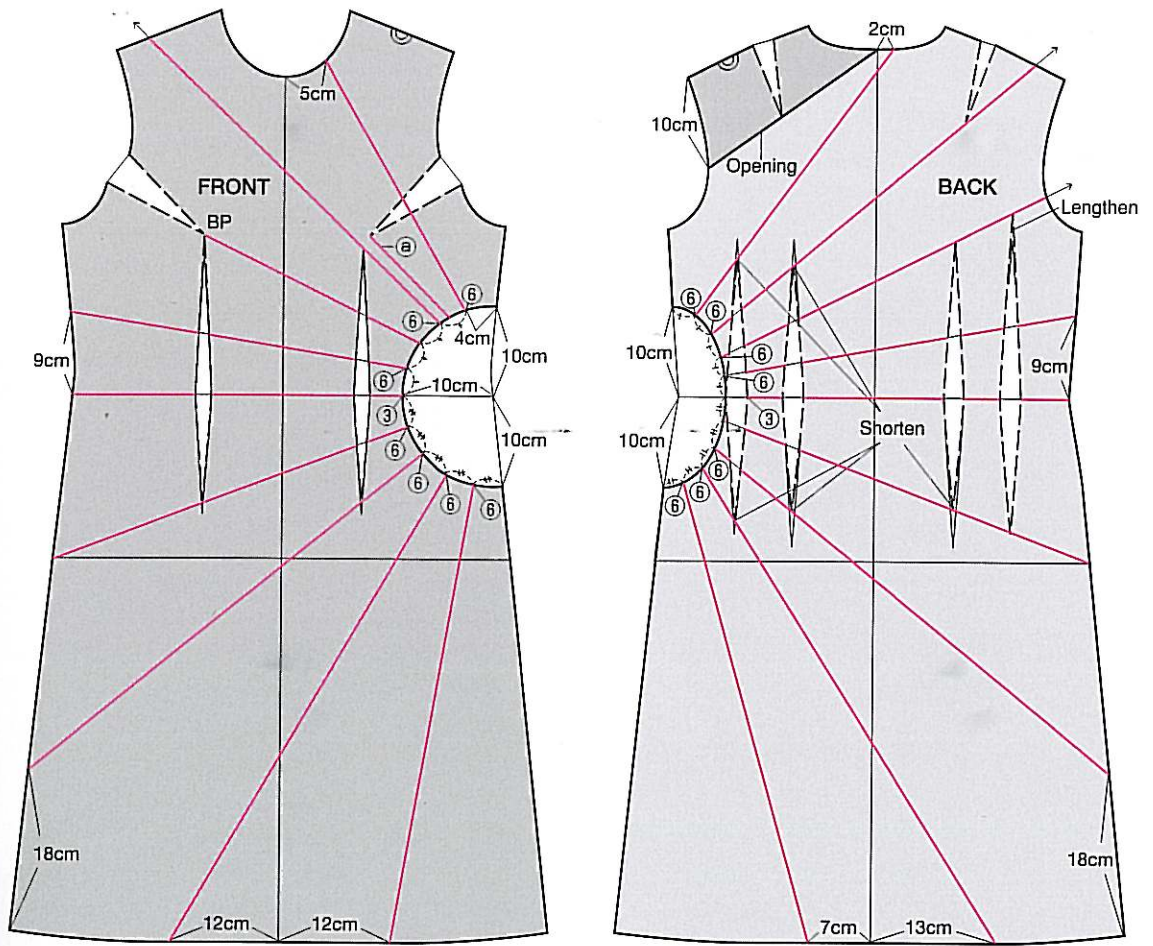

Ⓜ Because the left and right bodice panels are asymmetrical, align them and draw where you want to open the hole. Insert cutting and opening out lines in a radial pattern in a balanced way.

Where the cutting and opening out lines do not make contact with the point of the darts, adjust by making the darts longer or shorter.

Where the point of the dart is too far away, for example like the bust dart on the left bodice front in the drawing, you can also draw another cutting and opening out line as in Ⓜ.

Make an opening in the back left shoulder along the radial-pattern cutting and opening out line, and connect that section to the bodice front.



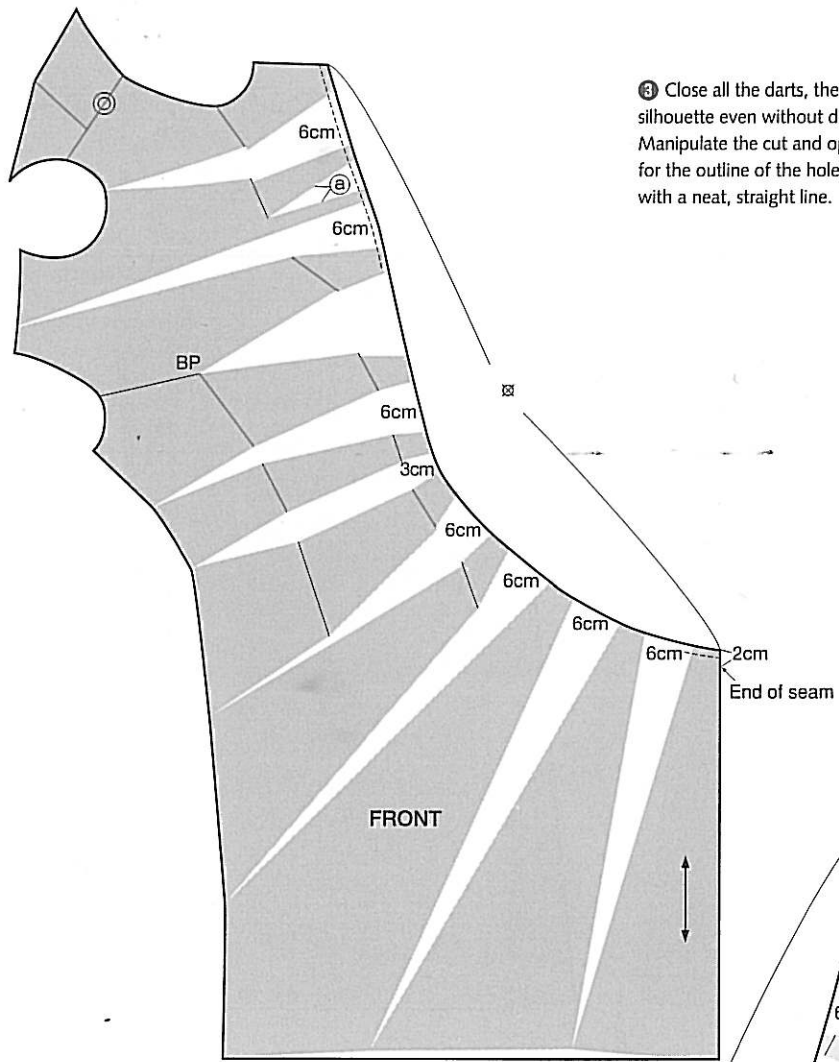

④ Close all the darts, thereby making it possible to create a fitted silhouette even without darts. Manipulate the cut and opened parts, to draw a smooth continuous line for the outline of the hole and the side seam. Then redraw the hemline with a neat, straight line.

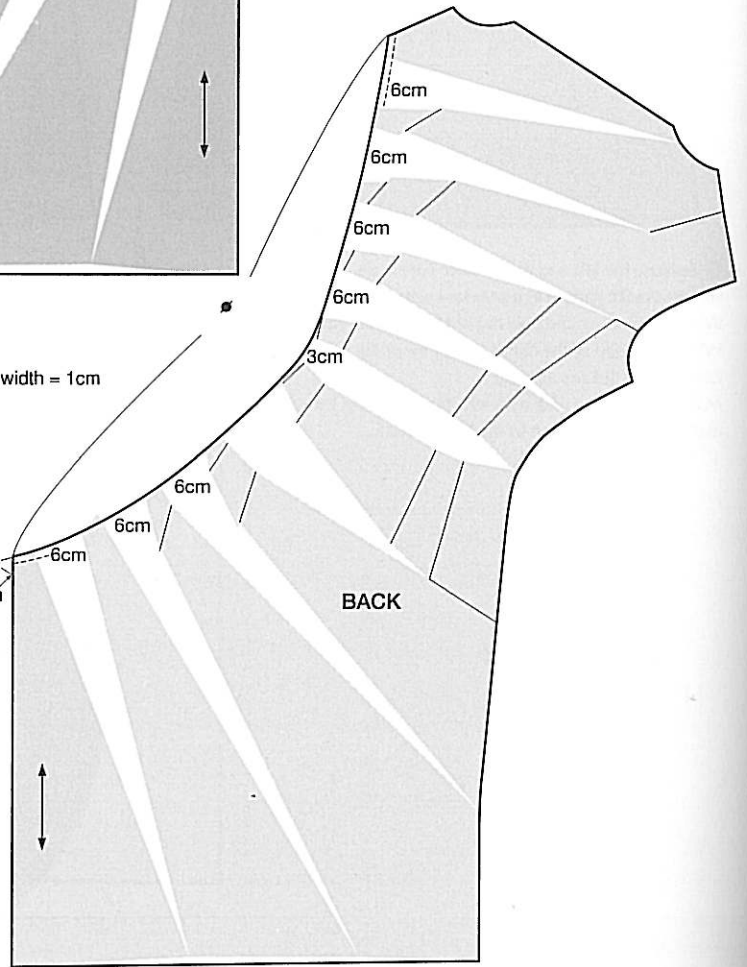

Top-stitch width = 1cm

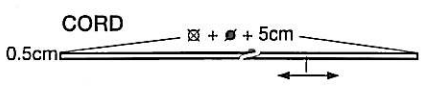

fitted

continuous line
the hemline

Page 15: Camisole with gathered hole

A design where the luxurious fabric used for the camisole is fitted to the body with design lines and appears to have sprung from the gathered hole.

It's made from cotton voile woven with dots and is great for wearing as casual wear, for example, with jeans.

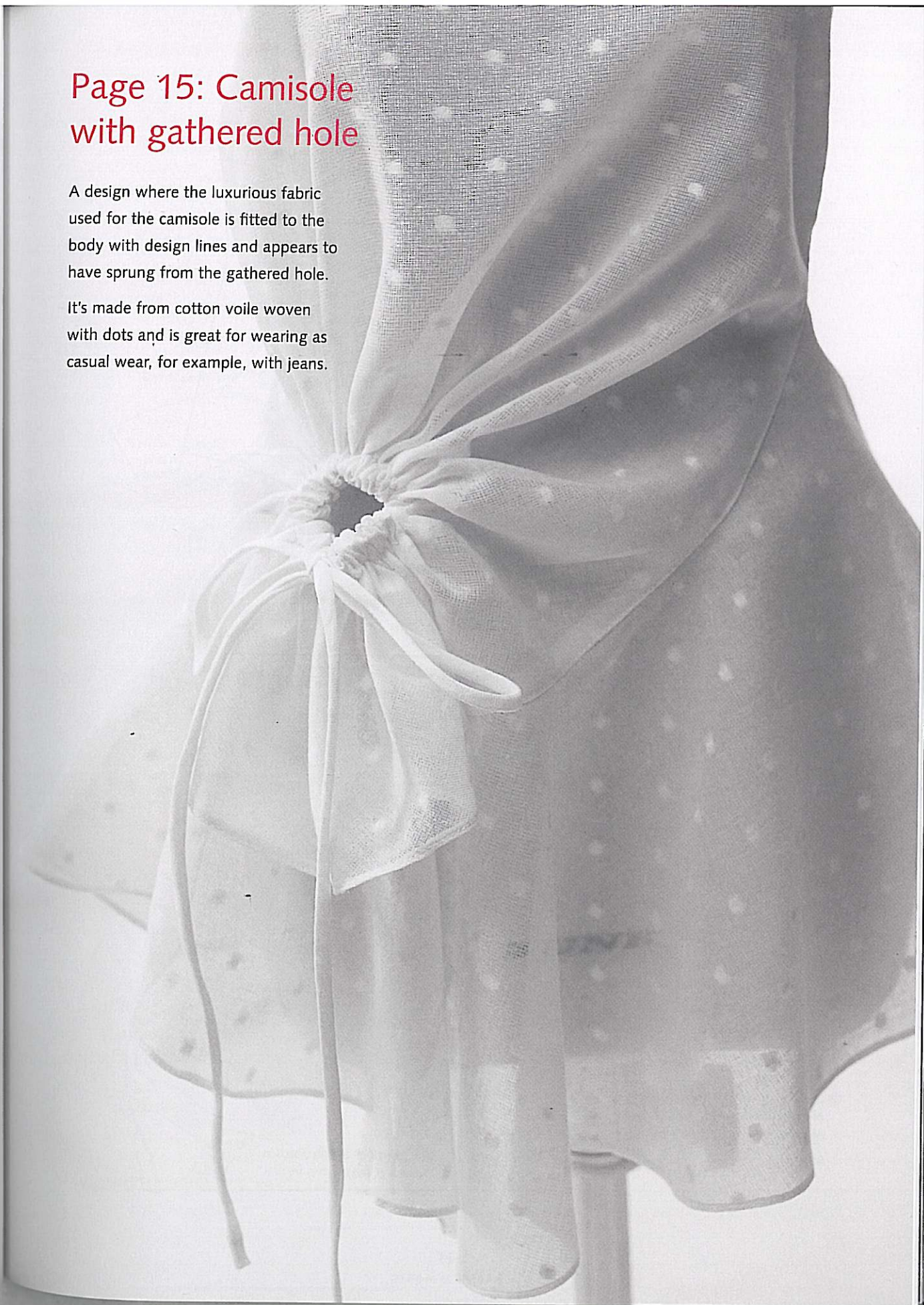
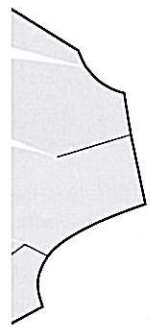

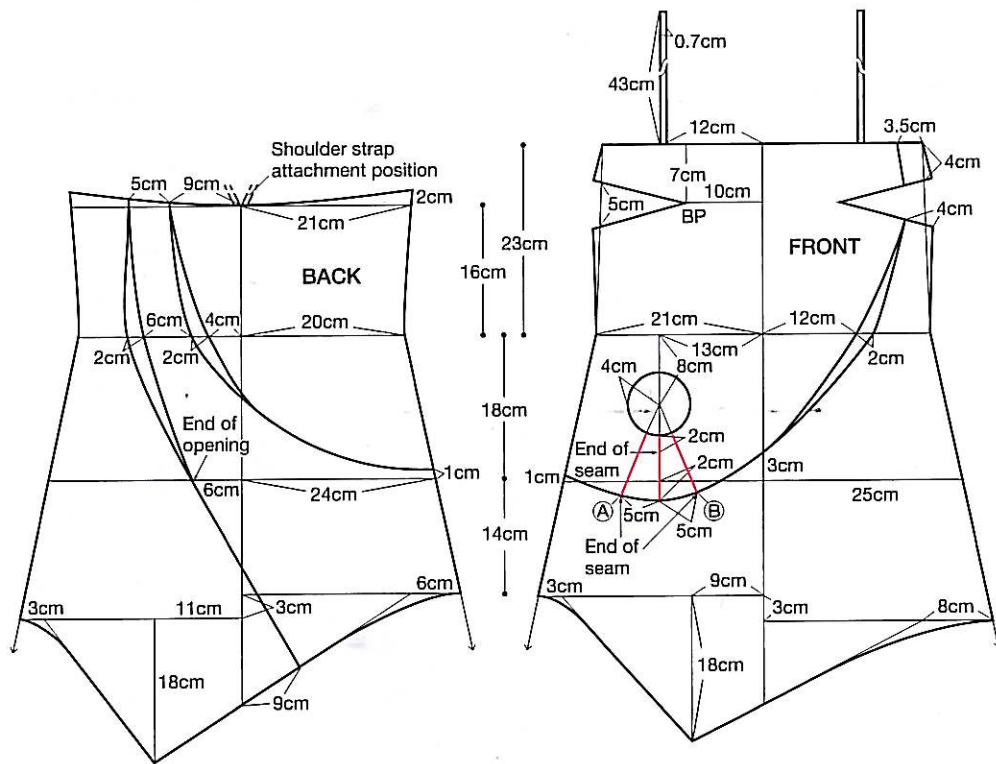

- ① Open a small hole for the gathering around the mid hip (MH) area of the right bodice front. Make a part of the gathering into a frill for greater emphasis. To create the frill strip, decide where the seam ends and do not sew beyond that point. Then make the frill, taking care not to attach it to the bodice. Fit the waist using the curved diagonal seams as design lines.

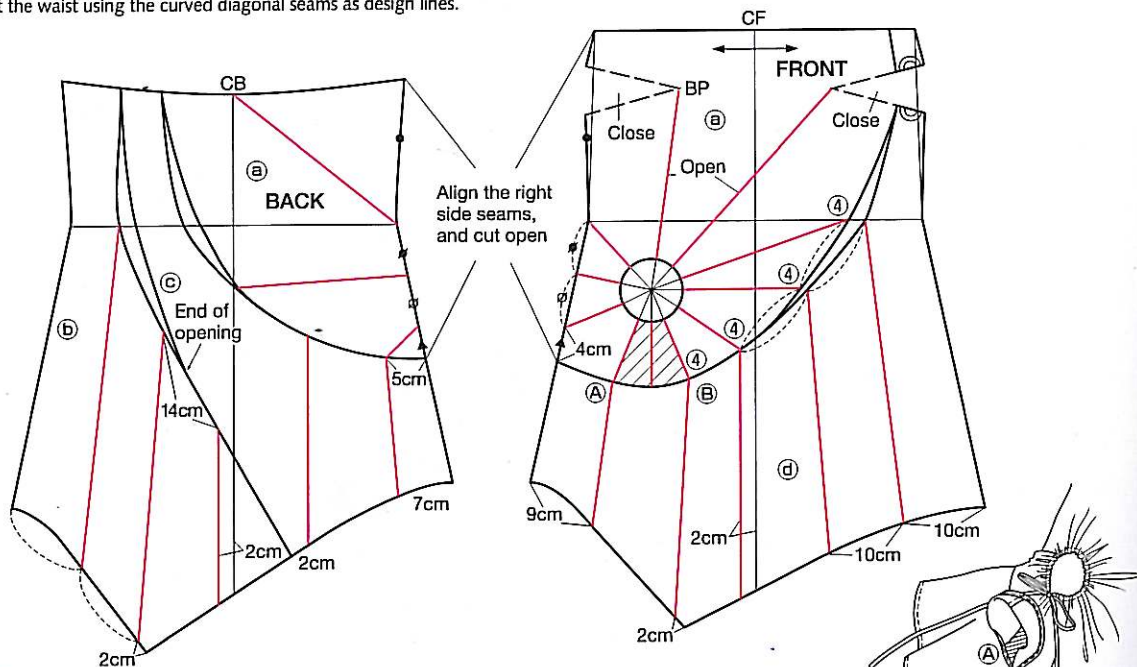

- ② Draw design lines for the gathering in a radial pattern in section (a) of the pattern where the hole has been made. Align the bodice front and back right side seams and insert the design lines.

Enlargement of the frilled section. The ends of the frill strip are not joined together.

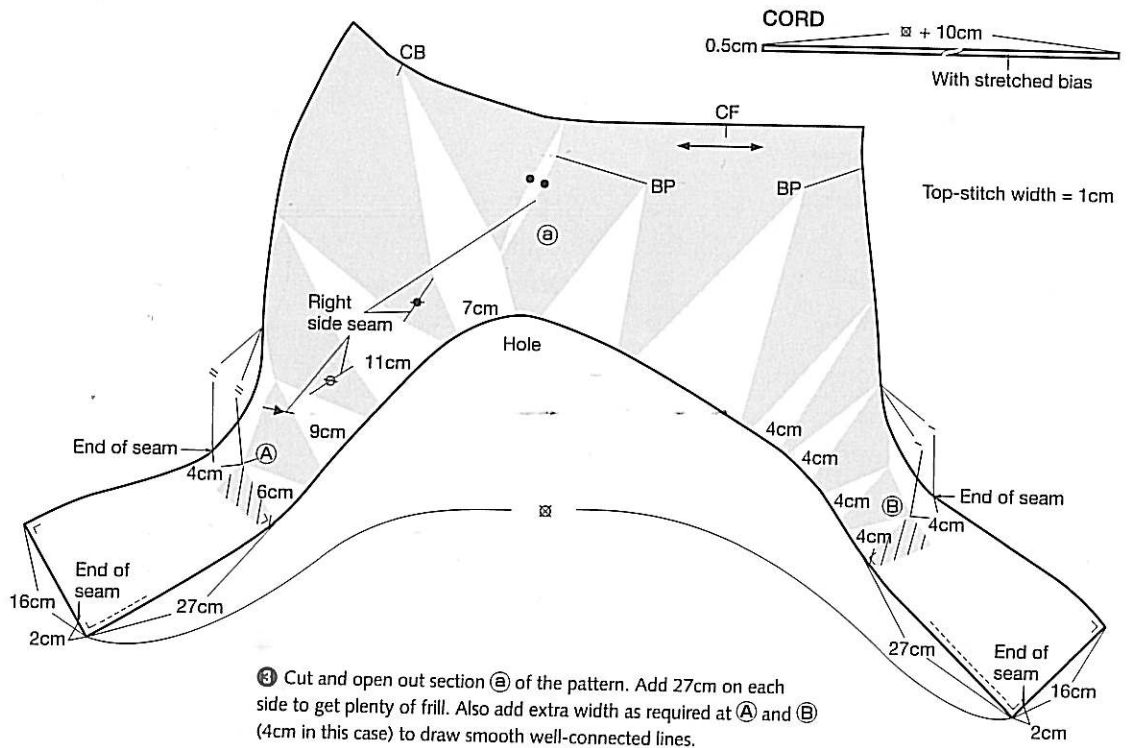

③ Cut and open out section ② of the pattern. Add 27cm on each side to get plenty of frill. Also add extra width as required at ① and ② (4cm in this case) to draw smooth well-connected lines.

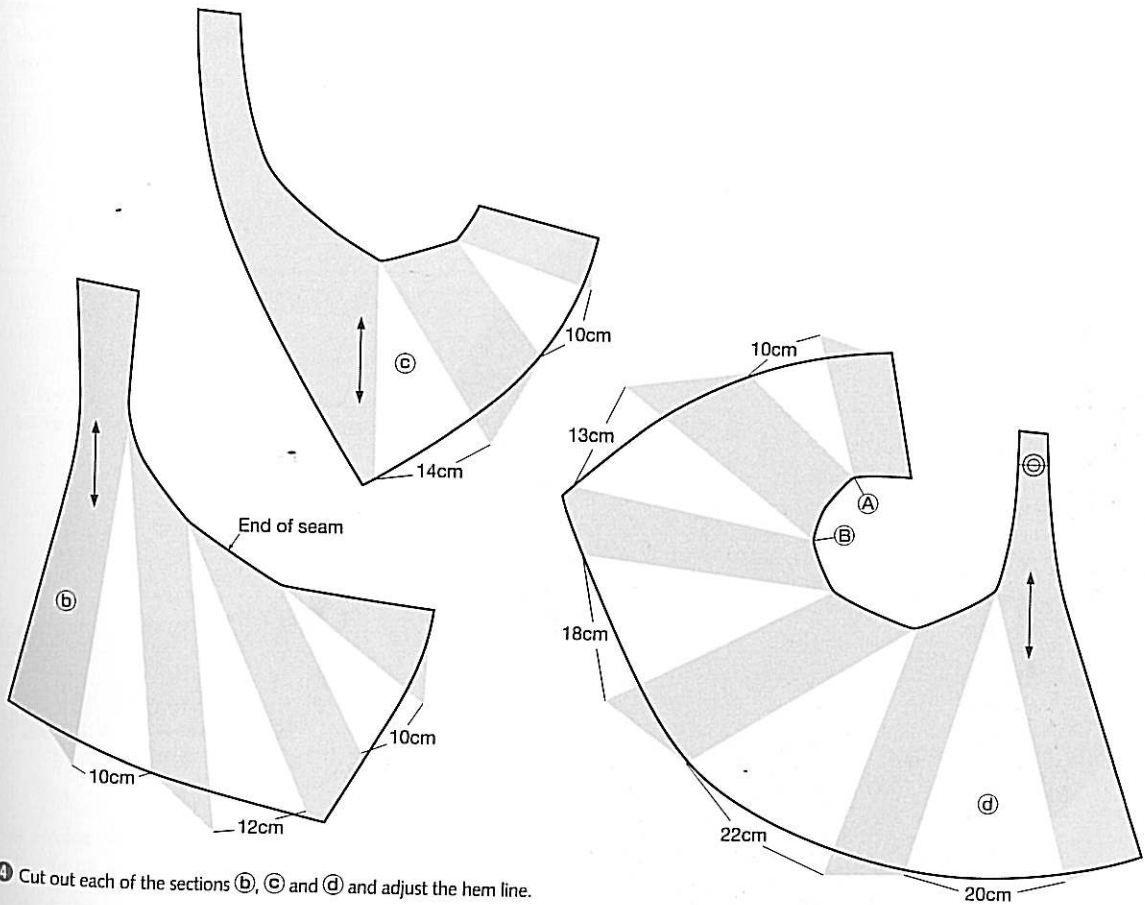

④ Cut out each of the sections ②, ③ and ④ and adjust the hem line.

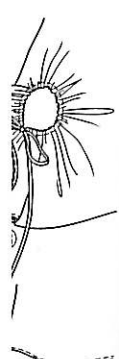

Page 17: Sleeve with gathered hole

A design for a close-fitting sleeve, with volume only in the top section of the sleeve. Visualize the finished silhouette of the sleeve to determine how much fullness must be added to the pattern.

Then, make the pattern, drawing the sleeve height in the same way as in the design drawing on the right.

Don't forget that the amount for cutting and opening out varies greatly depending on the fabric you have chosen.

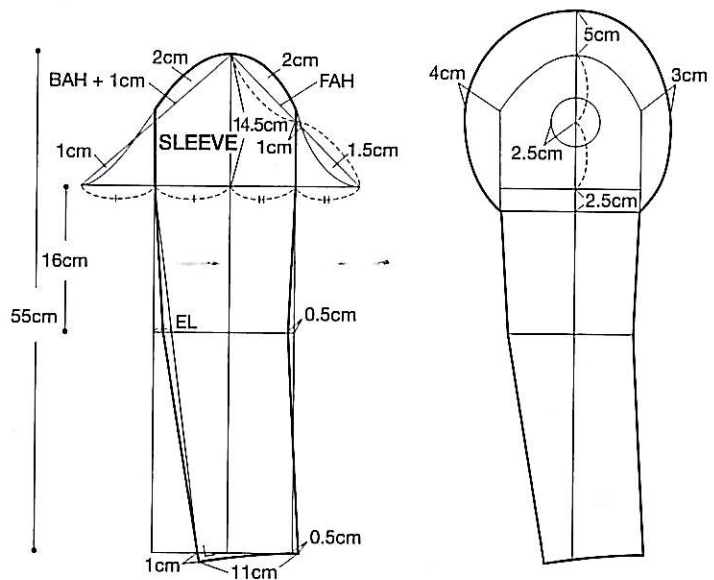

① Measure the armhole of the bodice and make a drawing for the sleeve.

② Draw the finished silhouette of the sleeve cap as seen from the side (the sleeve cap is flattened in the finished state).



3cm

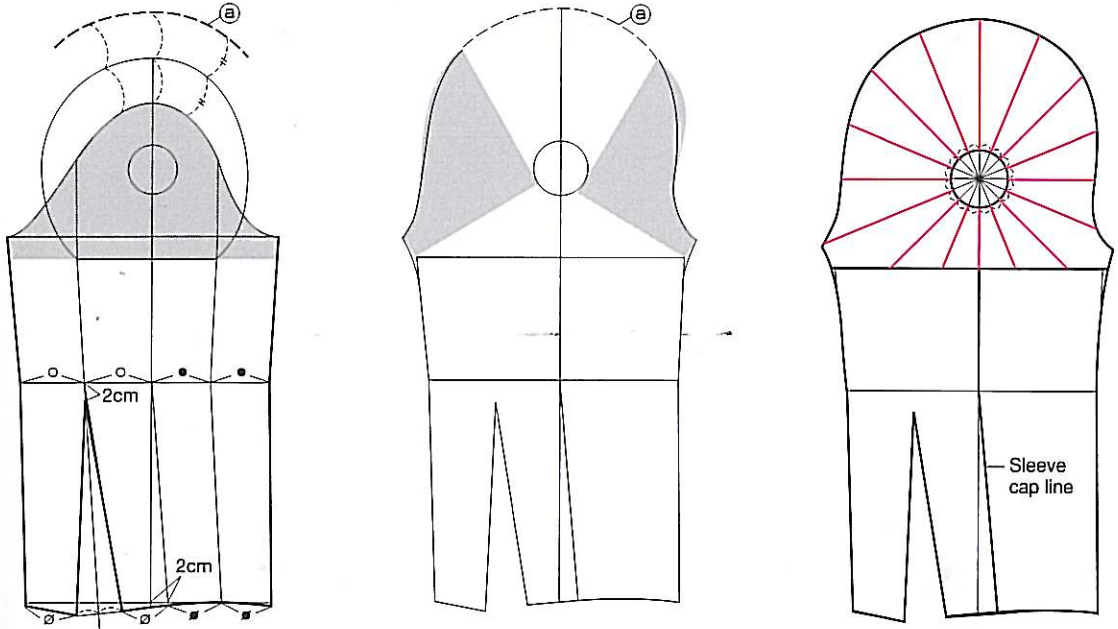

ite of the sleeve
e sleeve cap is
).

- ③ As shown in the diagram, draw the part of the sleeve cap that faces the neck by adding the same measurement as in ②. Draw the underarm line.
- ④ Cut and open out the sleeve cap until it reaches line ③ and draw a smooth, curved line.
- ⑤ Draw cutting and opening out lines in a radial pattern from the centre of the hole.

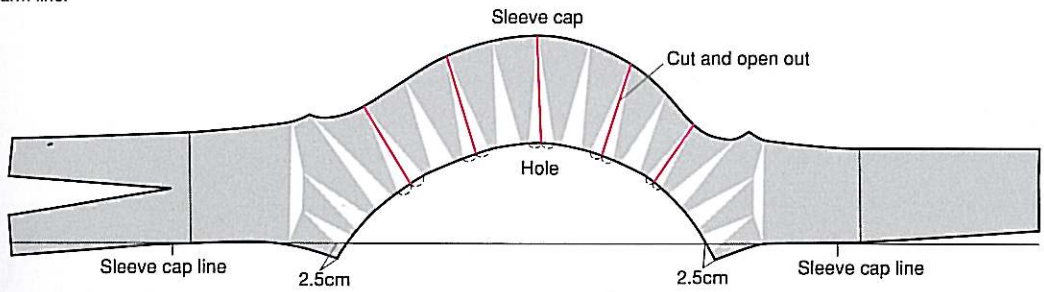

- ⑥ Firstly, with the sleeve cap attached, cut and open out until the sleeve cap line becomes horizontal. It is up to you to decide how much you want to open the sleeve cap, but consider the fabric grain, ease of sewing, and other factors.

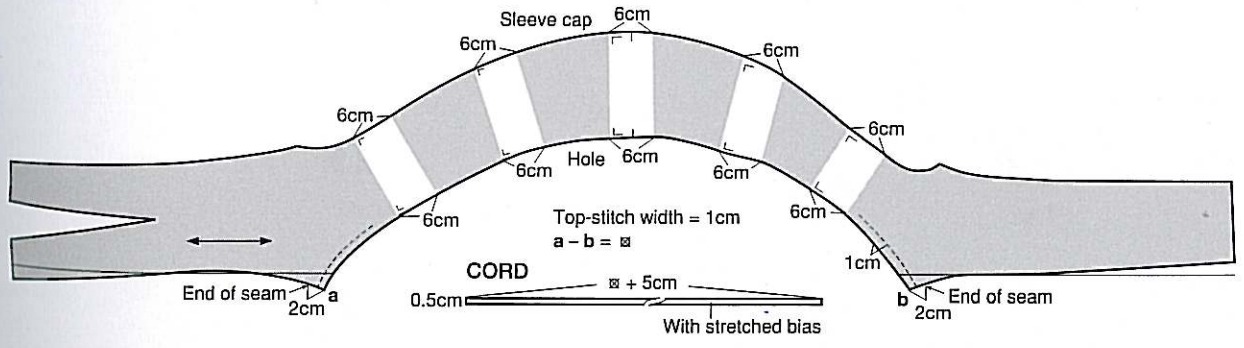

- ⑦ Because the amount for the gathering is still not sufficient, open out the sleeve cap even further. The amount for cutting and opening out varies according to the fabric used.

Crater

By inserting ease, the fabric was shaped into a gentle concave structure, resembling a crater on the surface of the moon. Use a sturdy fabric that can be eased into shape for a more dramatic appearance.

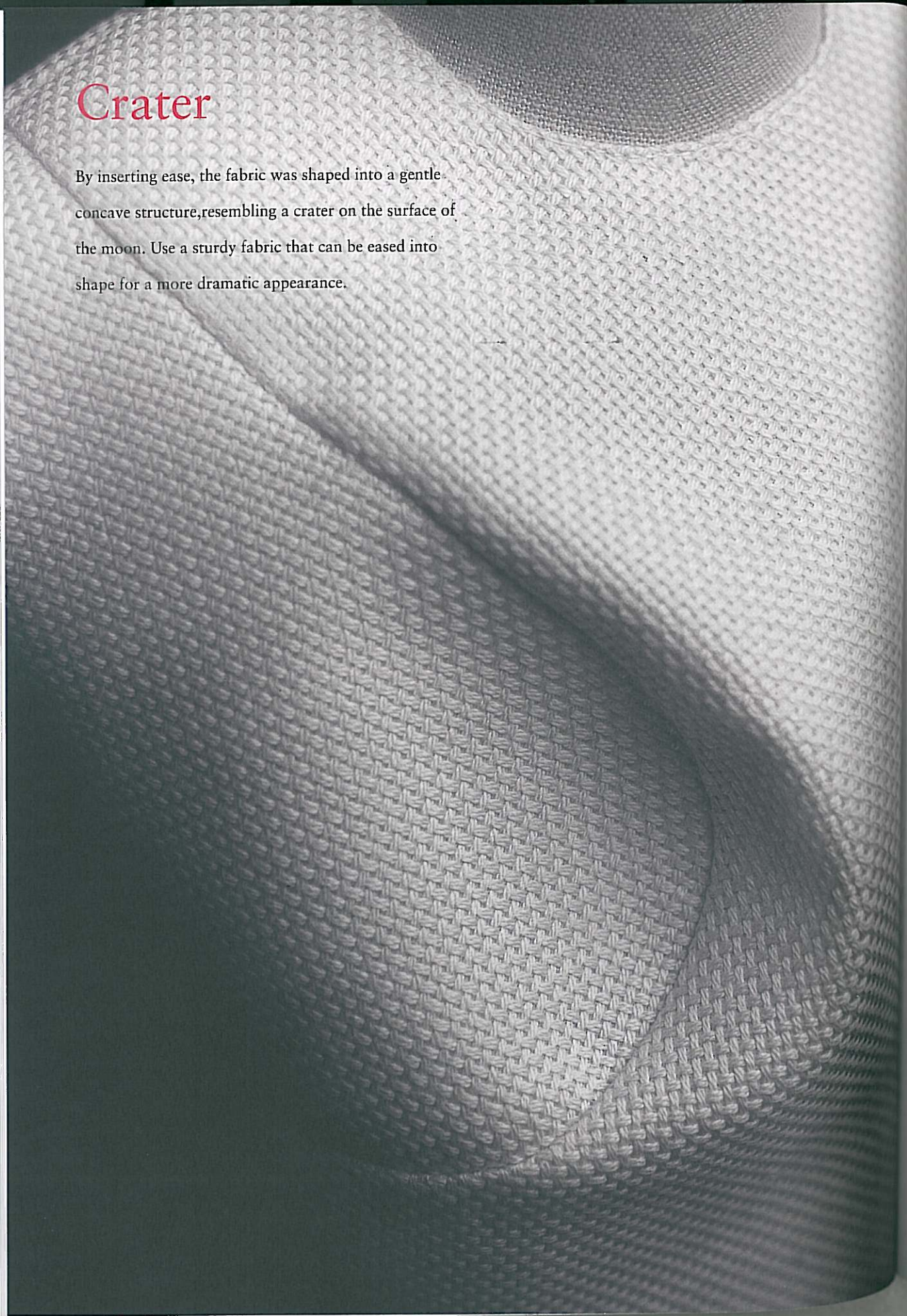

Page 16: Crater bodice

An elegant bodice that emphasizes the subtle movements of the fabric.

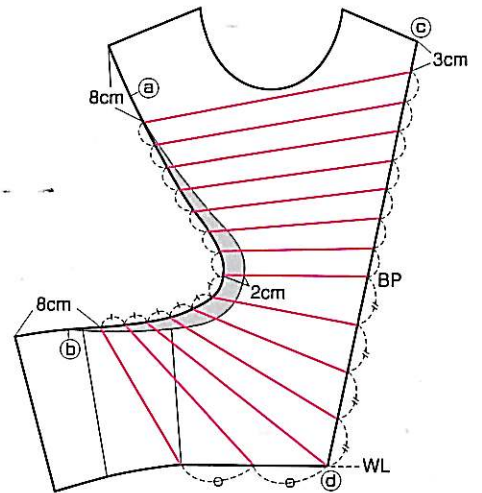
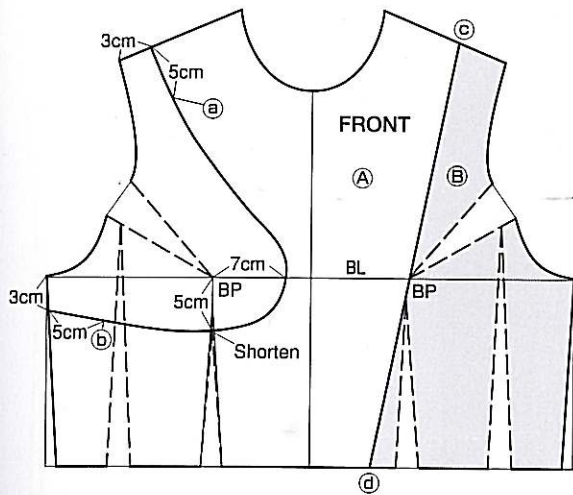

1 Insert the design lines for the "crater" and determine points (a) and (b), where the easing will end.
 (c)-(d) is the line from which the "crater" starts to swell. Draw (c)-(d) by extending the line that connects the points of the two darts.

2 Add 2cm at the bust line to add thickness to the "crater" and insert lines for cut and opening out as shown in the drawing.

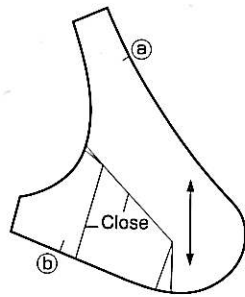

3 Close the darts on the section that forms the bottom of the "crater" on the bodice right panel.

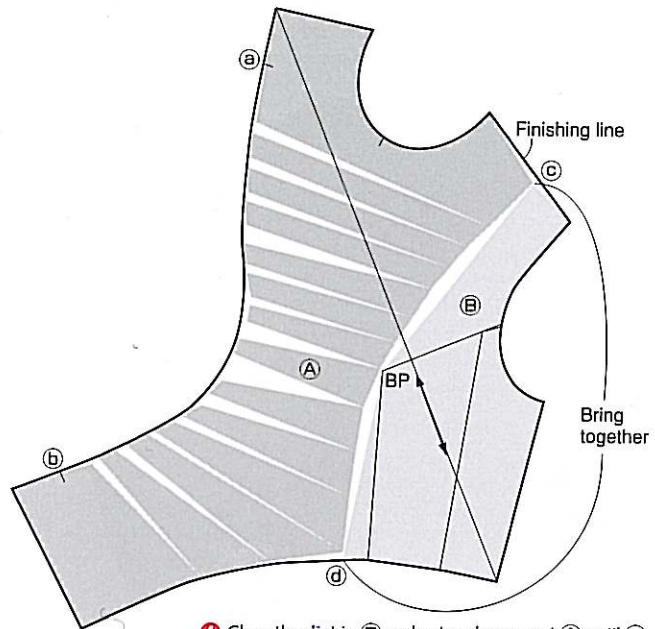

4 Close the dart in (b) and cut and open out (A) until (c)-BP-(d) aligns with (b). Align (A) and (B) as shown in the drawing to make one pattern. The difference in length between (a) and (b) on the bodice left and right panels is the amount of ease. Use fabric cut on the bias so that it is easier to insert ease.

Page 17: Crater sleeve

A sleeve with structural interest where a dent has been made in the fabric on the sleeve cap.
An interesting design for a simple jacket or coat.

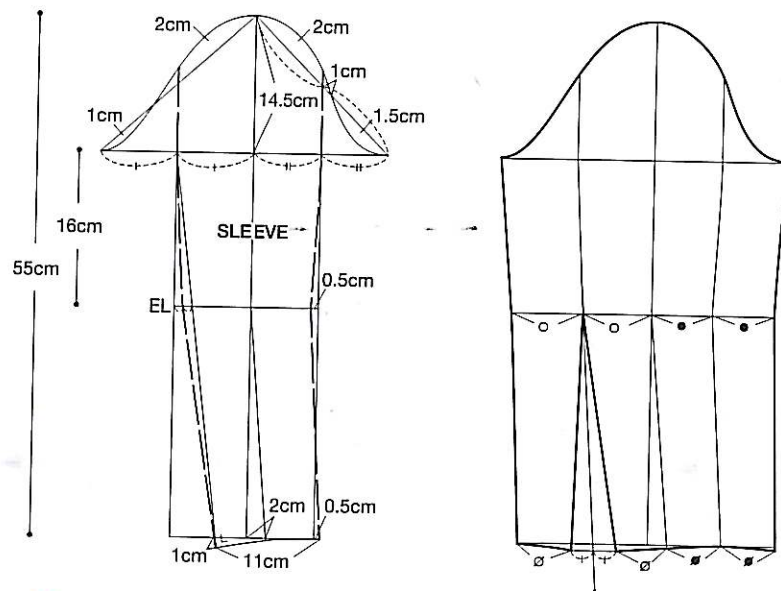

① Draft the basic sleeve pattern. Draw the shape of the sleeve cap. Connect the point where the sleeve width on either side of the sleeve-cap line has been divided into two equal sections and the sleeve opening width measurement. Draw the line with a slight outward curve at the EL to create the shape of the natural arm.

② Open symmetrically at the fold line to make a one-piece sleeve.



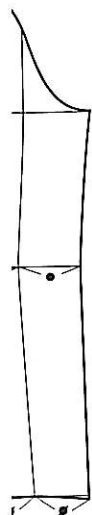

d line to make

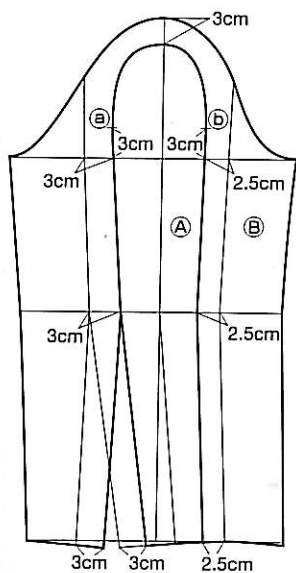

3 Move the design lines for the "crater" inward from the sleeve fold lines, and divide the sleeve pattern into two panels, (A) and (B). Mark points (a) and (b) to indicate the area to be eased. Moving the design lines inward also has the effect of making the arm appear slimmer.

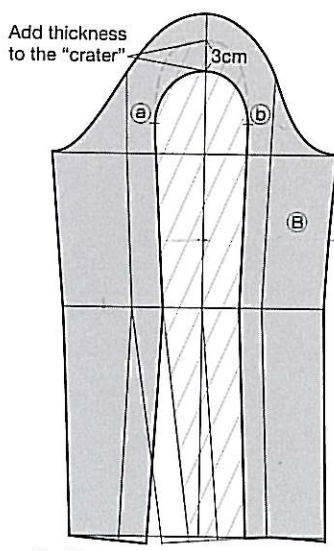

4 Add 3cm to increase the thickness of the "crater" in the area between (a) and (b) on panel (B).

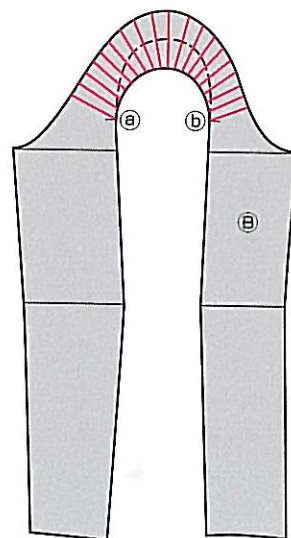

5 Draw lines for cutting and opening out in a radial pattern in the area between (a) and (b) on panel (B).

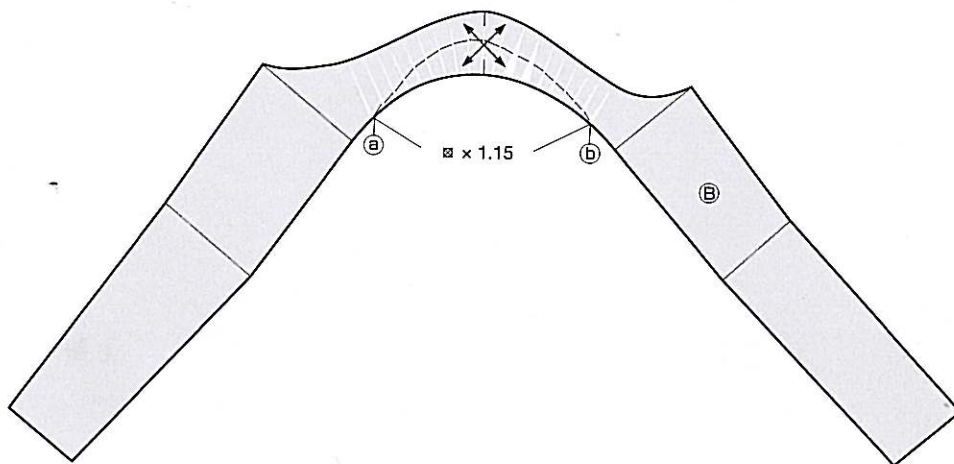
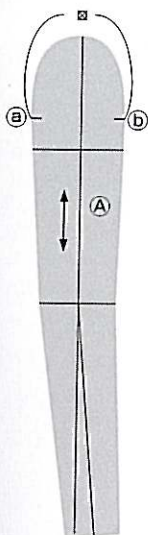

6 Make the perimeter of the curved line between (a) and (b) on panel (A) into \varnothing . Cut and open out panel (B) as shown in the drawing. The amount to be opened out varies according to the fabric used, but here about 15 percent of \varnothing has been opened. The amount that has been opened out is eased to create an elegant silhouette.

The drop hole (*otoshiana*)

The *otoshiana* technique was developed from the idea of connecting two holes to form a tunnel-like structure.

As the *otoshiana* is a complex design, we start by assembling it out of paper.

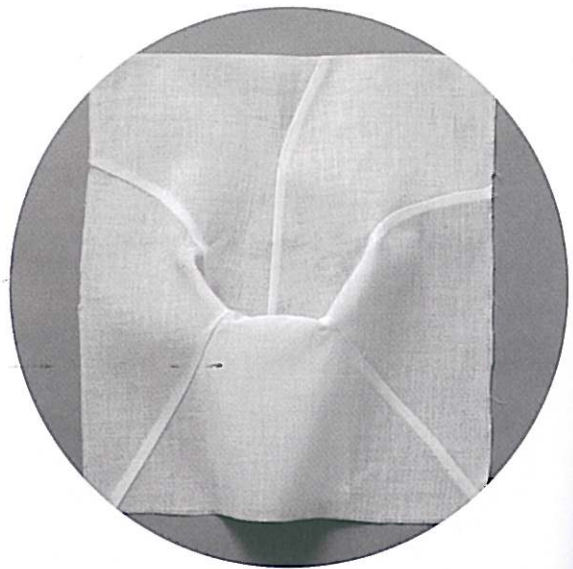

Assembling the *otoshiana*

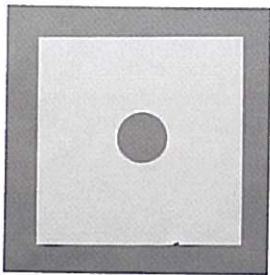

① Open a hole of the desired size on the paper.

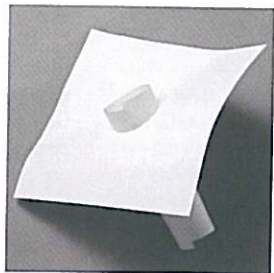

② Make a paper pipe and place it in the hole. Decide on your desired angle and the length for the pipe.

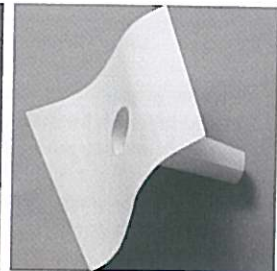

③ With scissors cut off the part protruding from the top of the paper.

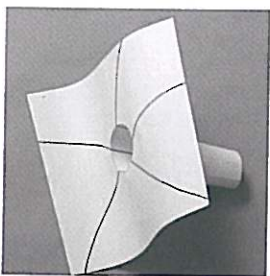

④ Insert the design lines.

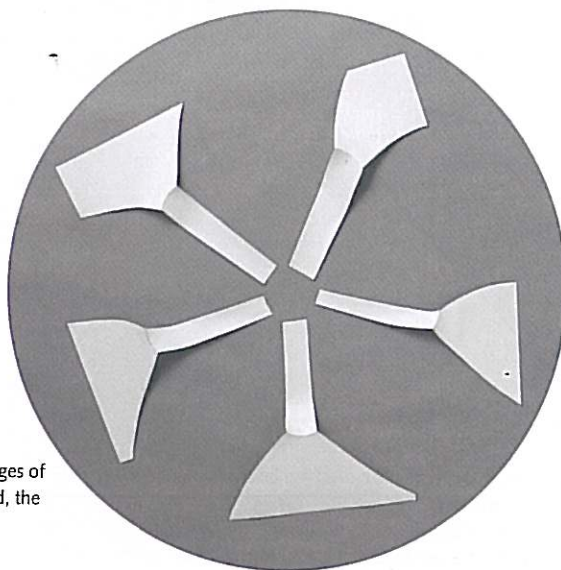

⑤ Cut along the lines. Because the edges of the paper parts and the pipe are curved, the excess amount does not lie flat.

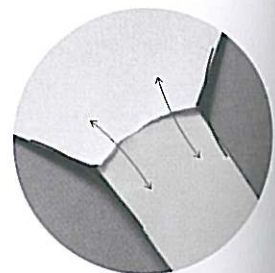

⑥ Fold the excess on both sides and redraw the lines. The amount added in this way makes the entrance to the hole looser, or sharper, and the look changes.

Page 18: Skirt with an *otoshiana*

Here the *otoshiana* technique is applied to a skirt.

The basic *otoshiana* was assembled on a muslin (toile) to make a pattern.

The more volume the silhouette of the skirt base has, the more three-dimensional the *otoshiana* looks and the more it stands out.

The sturdy fabric I have used here is a bonded fabric of mesh and urethane.



of the paper.



ess on both
w the lines. The
in this way makes
the hole looser,
the look changes.

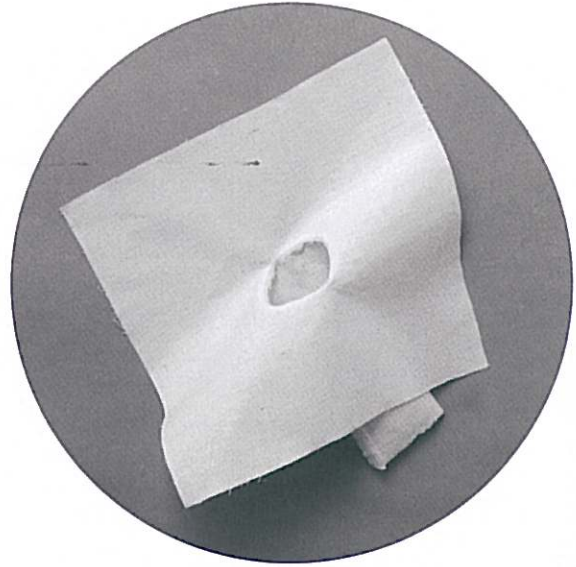

① Make a muslin (toile) for the skirt base. The pattern for the skirt in the picture is shown below but you can make the skirt any shape you want.

② In the same way as with paper on page 42, insert the tube through a fabric base to create the *otoshiana*.

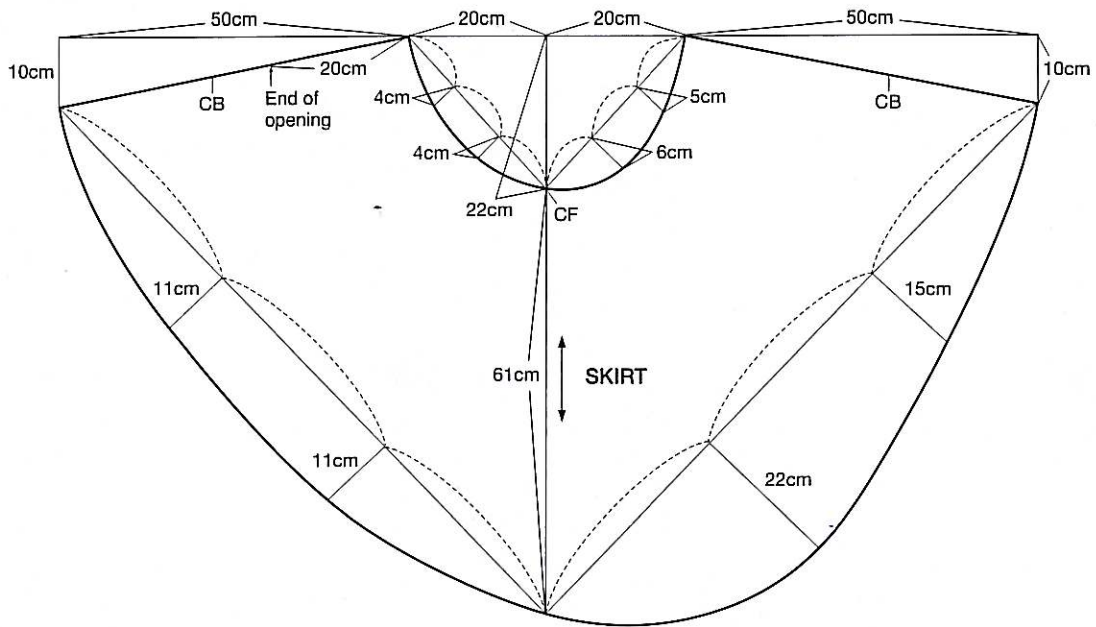



3 Open a hole where you want to position the *otoshiana* in the skirt. The hole can be of any size, but remember to make it larger than the circumference of the end of the tube and smaller than the fabric base.

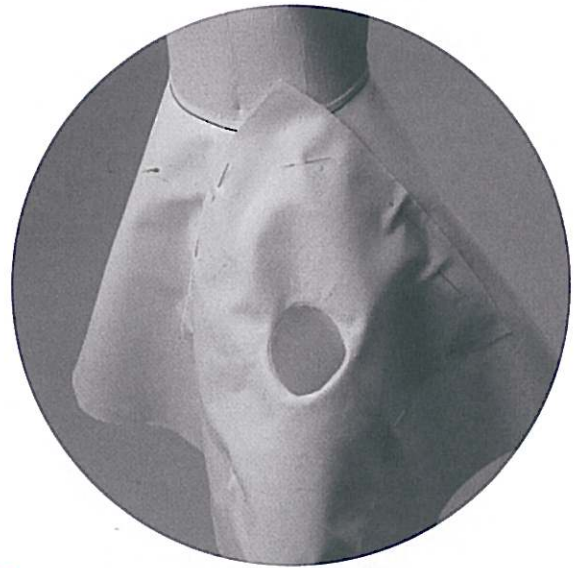

4 Insert the assembled *otoshiana* into the hole in the skirt and create your desired silhouette.



5 Fasten the fabric base to the skirt with pins, and machine-stitch to attach.

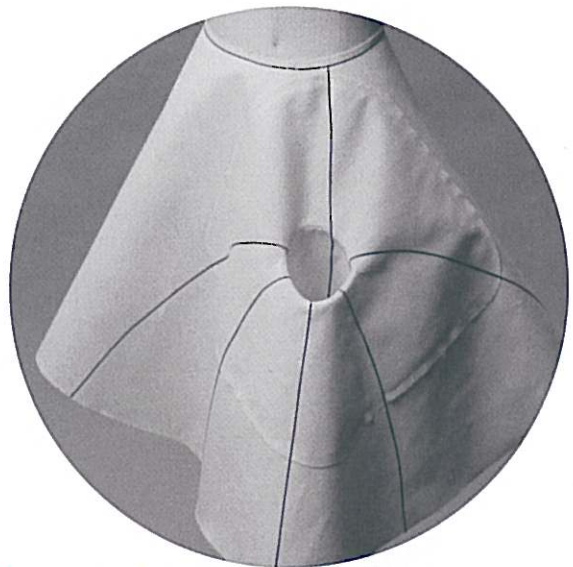

6 Insert the design lines here, considering how best to focus on the *otoshiana*.

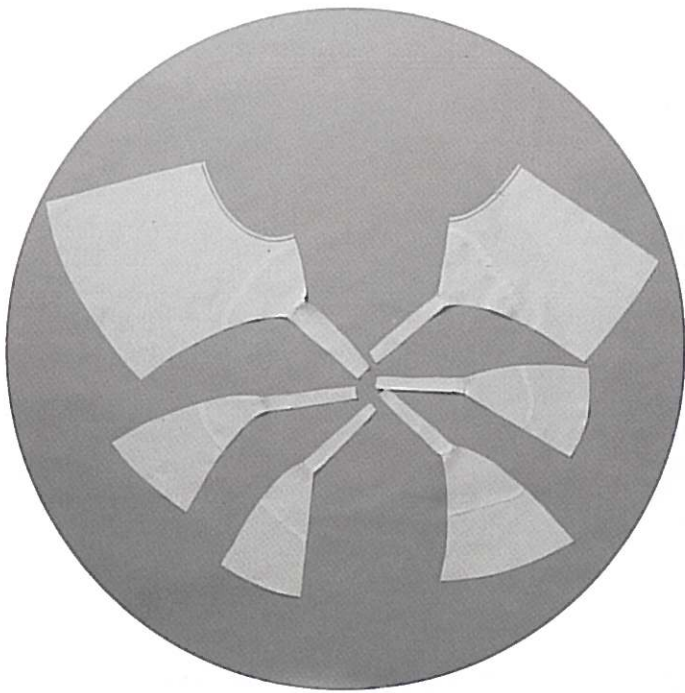

7 Cut along the design lines to make the fabric pattern. Where the edges of the hole do not lie flat, fold the pattern and adjust the line.

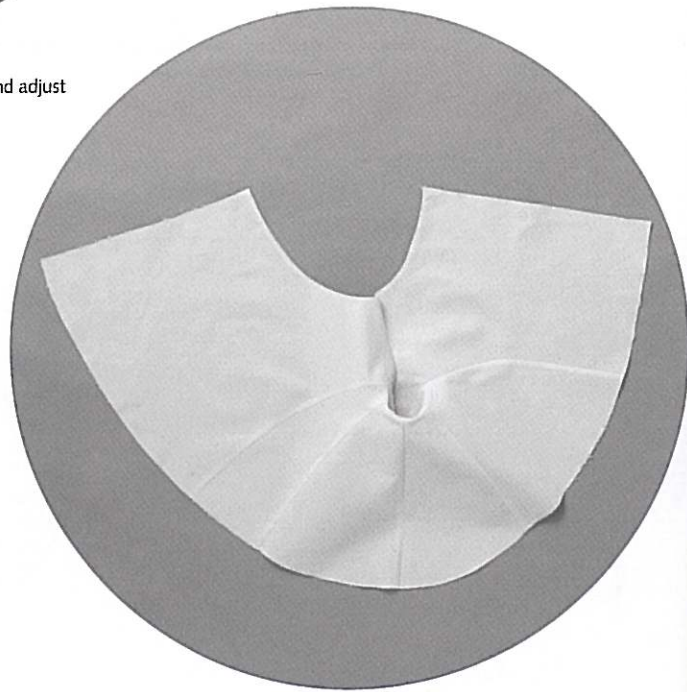

8 Open out and iron the folded parts, then machine-stitch for a smooth, continuous line.

Page 19: Dress with an *otoshiana*

This dress features two *otoshiana* connected on the inside to form a tunnel.

This is a complex pattern, using the basic *otoshiana* technique.

For this distinctive design, I chose a coarse woollen fabric, in a neutral color, that is easy to ease and stretch.

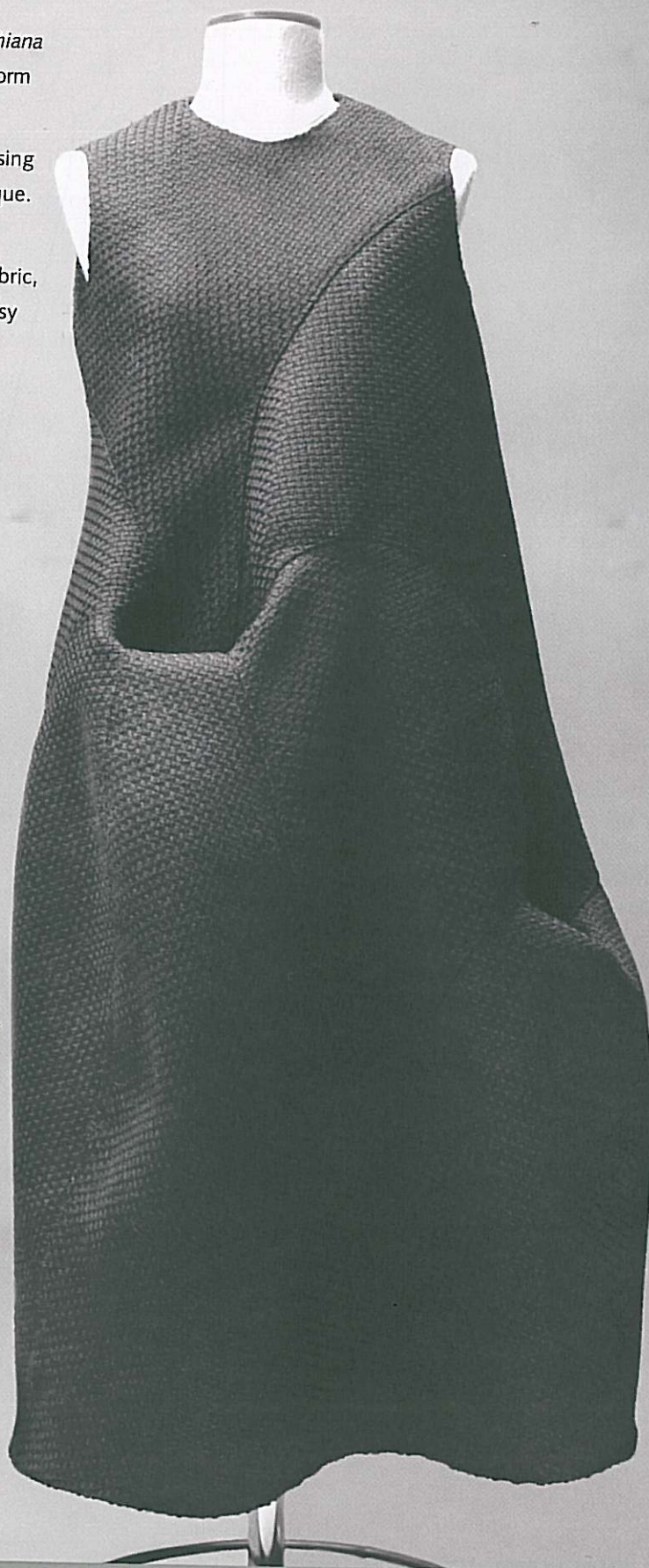

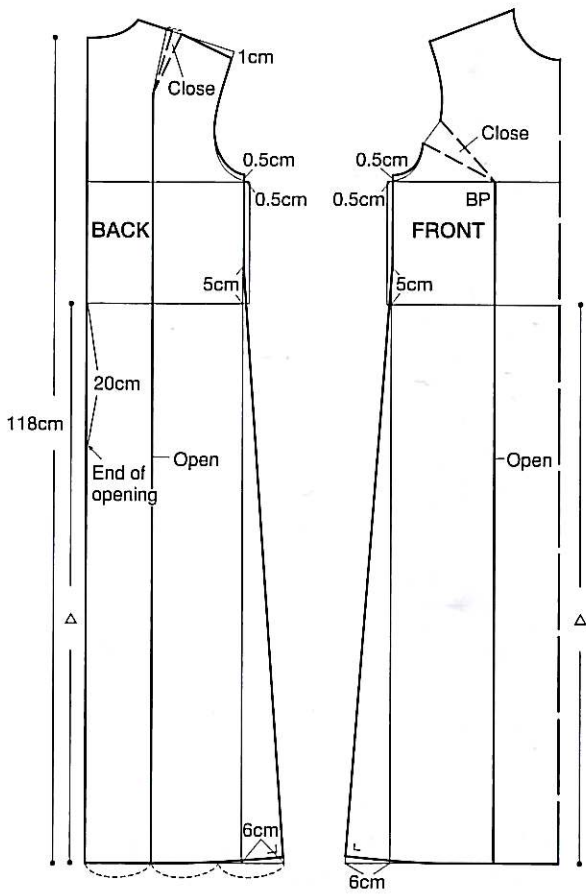

① Using a sloper (block), close the darts and cut and open out. A base pattern for a simple dress that has neither darts nor design lines.

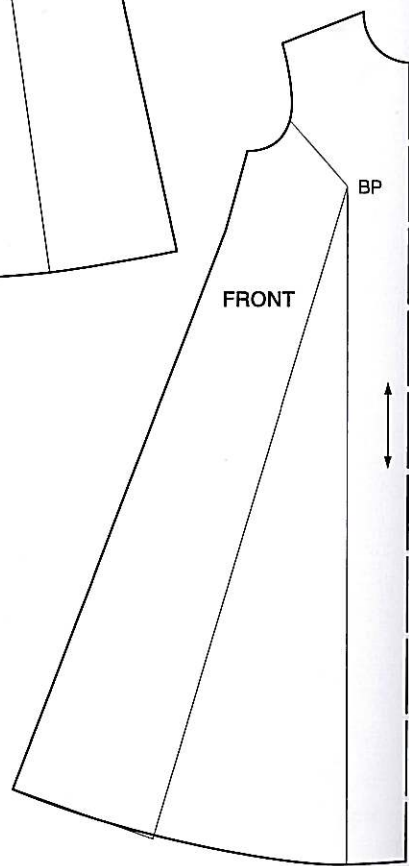
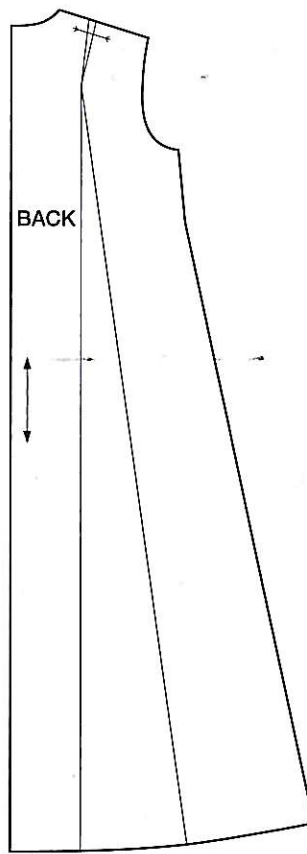

② Decide on the two places for positioning the holes and make a muslin (toile) following the order of pattern-making for a skirt.



① Assemble out of paper

④ Insert lin
The pattern
pass through
dimensional

Lumps and bumps (*dekoboko*)

This technique evolved from an idea to incorporate a *dekoboko* (an uneven surface) decoration into a garment.

Attaching cubes onto a base is in itself interesting, but when the cubes are connected with design lines, the undulating lines come alive.

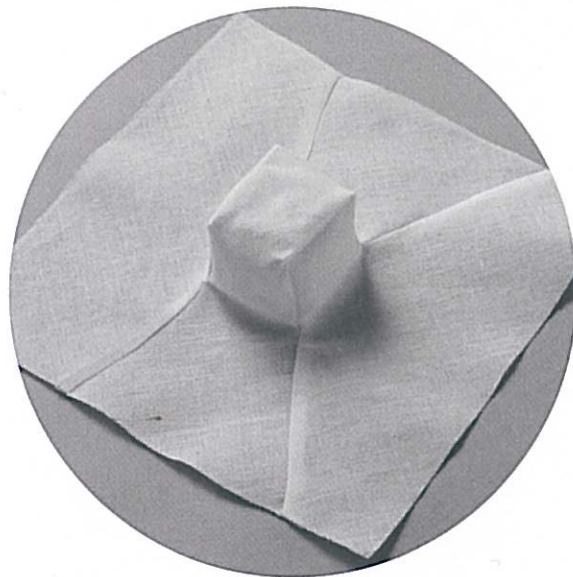

Making a pattern for the *dekoboko* out of paper

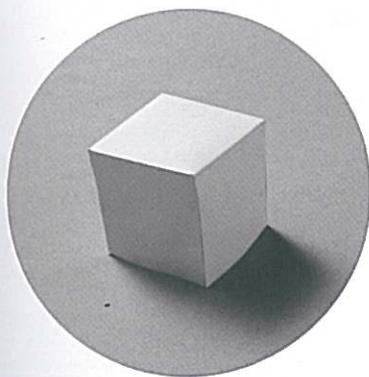
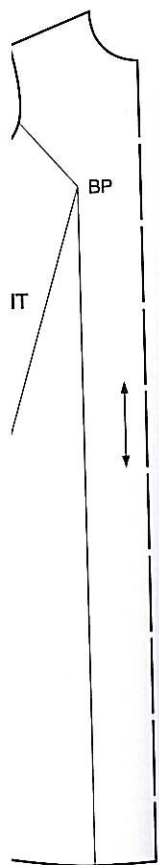

1 Assemble a three-dimensional object made out of paper in any size you want.

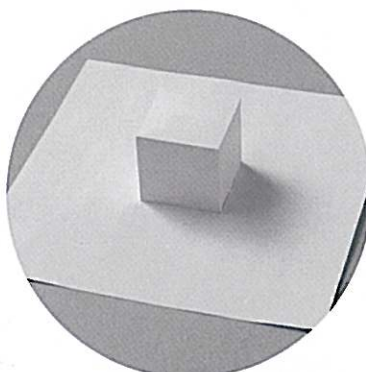

2 Attach to the paper base. Think of the paper base as the garment.

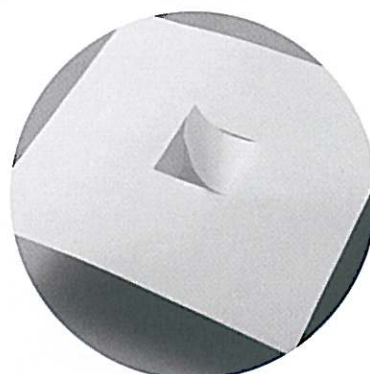

3 Cut away the bottom of the base. From the top, it is convex and from the bottom, concave.

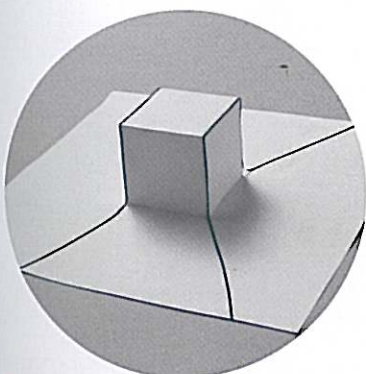

4 Insert lines in any way you want. The pattern is easier to make if the lines pass through the corners of the three-dimensional object.

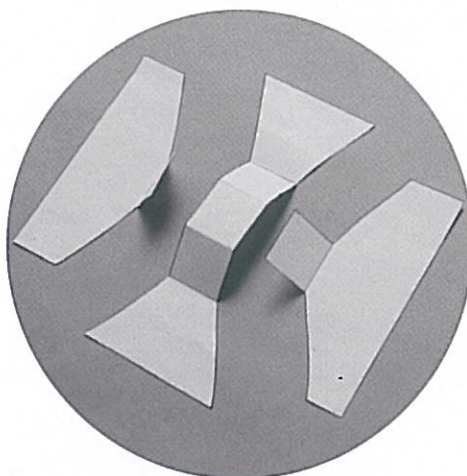

5 Cut along the lines, open and flatten out.

and make a muslin



Page 20: A *dekoboko* bodice

Three cubes on a bodice that is based on a sloper (block).

Various looks can be created according to how you insert the design lines.
You can also change the colors of the various elements.

The cubes are best expressed in a somewhat sturdy fabric.

Ma
thr

① Ran
(block)

Making a pattern with the three-dimensional paper objects

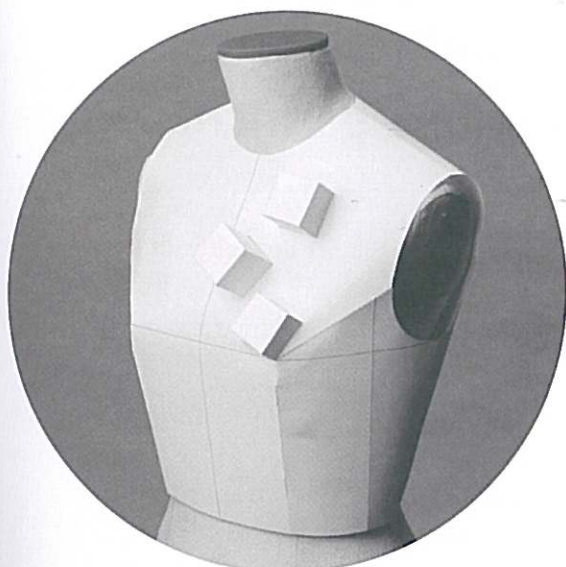

① Randomly attach the cubes at different heights to the bodice sloper (block) made out of paper.

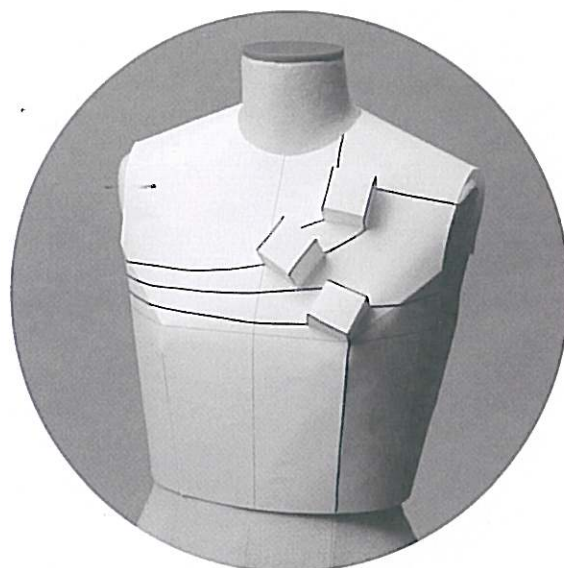

② Draw the design lines in any way you want, joining together the cubes.

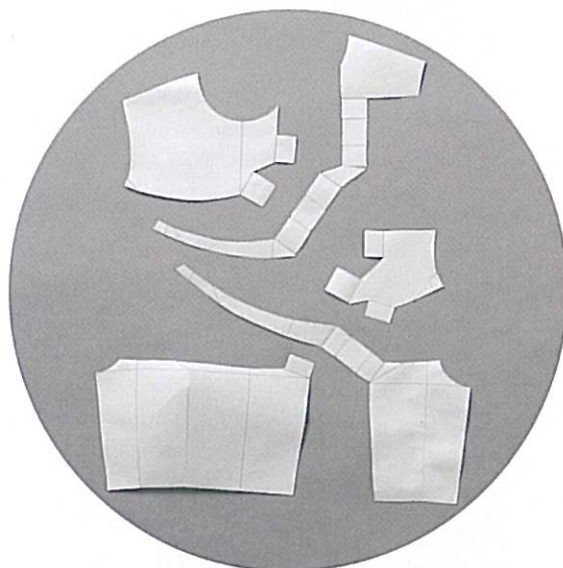
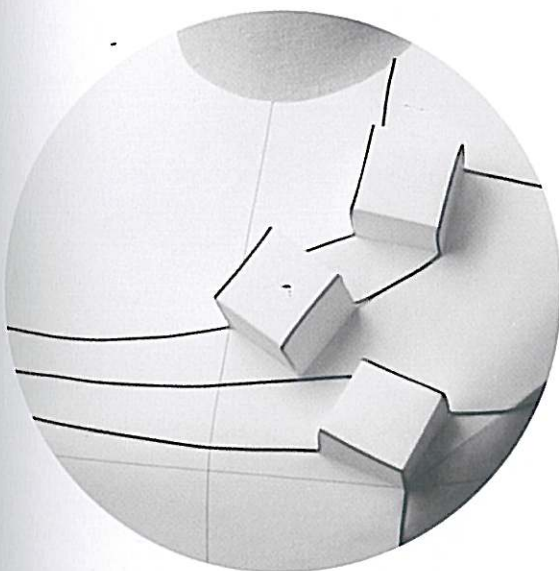

③ Cut along the lines and open to create the pattern. Where the design lines do not pass through the corners of the cubes, the pattern will not lie flat. Use one of the three basic techniques: inserting darts, easing, or flattening, to make the pattern lie flat.

Part 2

Making patterns for haute couture garments

When I was a student, I remember how difficult it was learning pattern-making off the blackboard.

I achieved the shapes I wanted by making miniatures out of paper, flattening them out by

inserting lines and cutting them to make a pattern.

It gave me a great feeling of satisfaction,

but I knew that, logically, it was a dubious way of going about it.

Playing around with patterns enables us to produce many more designs for couture garments.

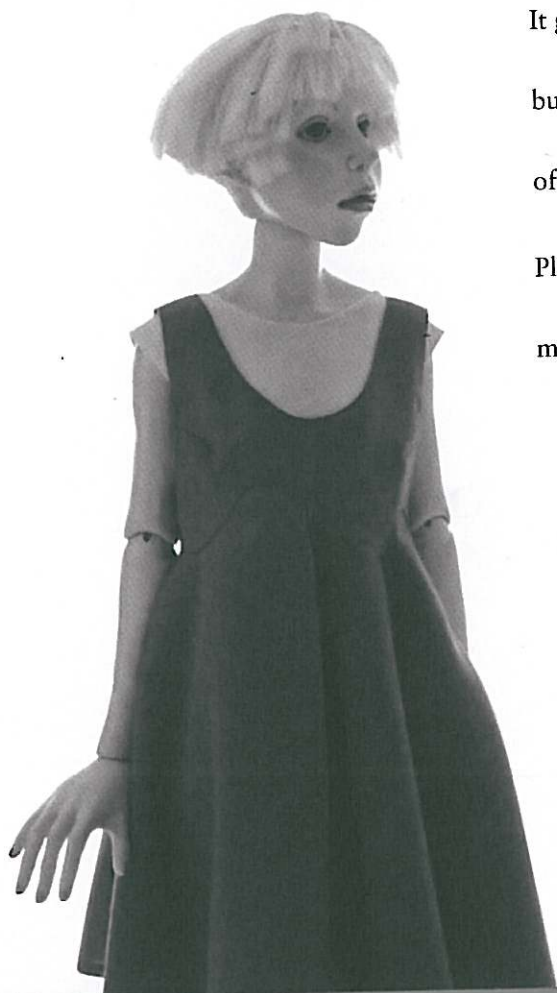

t it was

atures

ern.

7

duce



Dress with a draped design (See page 66 for instructions)

PATTERN MAGIC

Making a pattern

Clothes are a way of expressing oneself,

and with this in mind

I'm often inspired by fashions of the past.

To discover how they were made,

I try drafting the patterns myself, and

sometimes come up with designs that are

entirely my own.

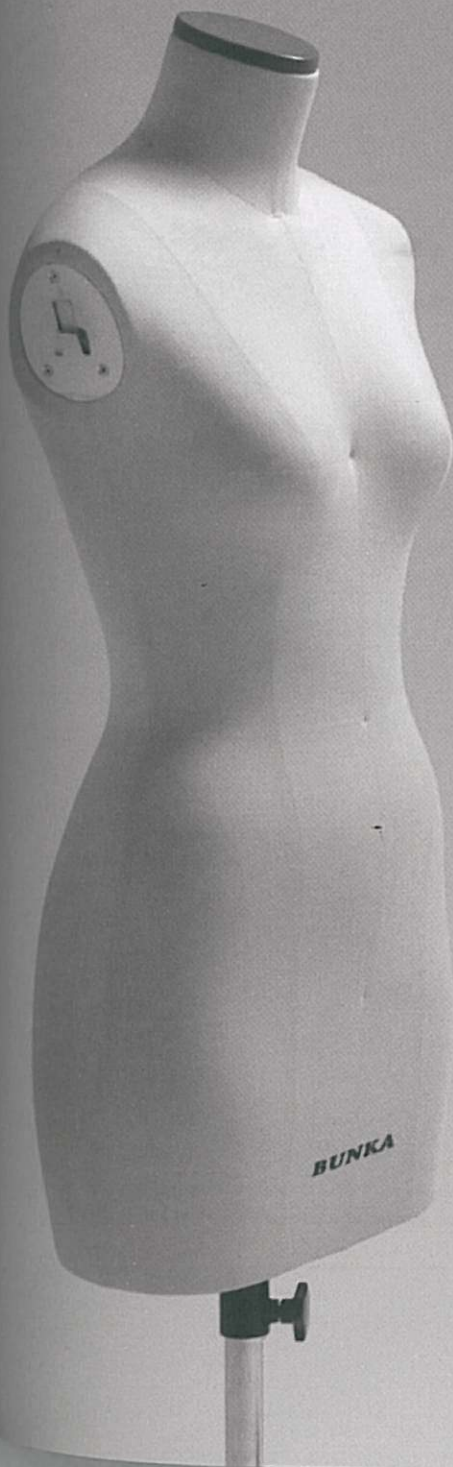

Draped design

An elegant contrast created by light and shade.

Make an easy-to-draft flat pattern

for a draped design that is usually produced by pinning and three-dimensional cutting of fabric.

A right and left intersecting whirlpool drape has been inserted into the sloper bodice.



Making the basic pattern

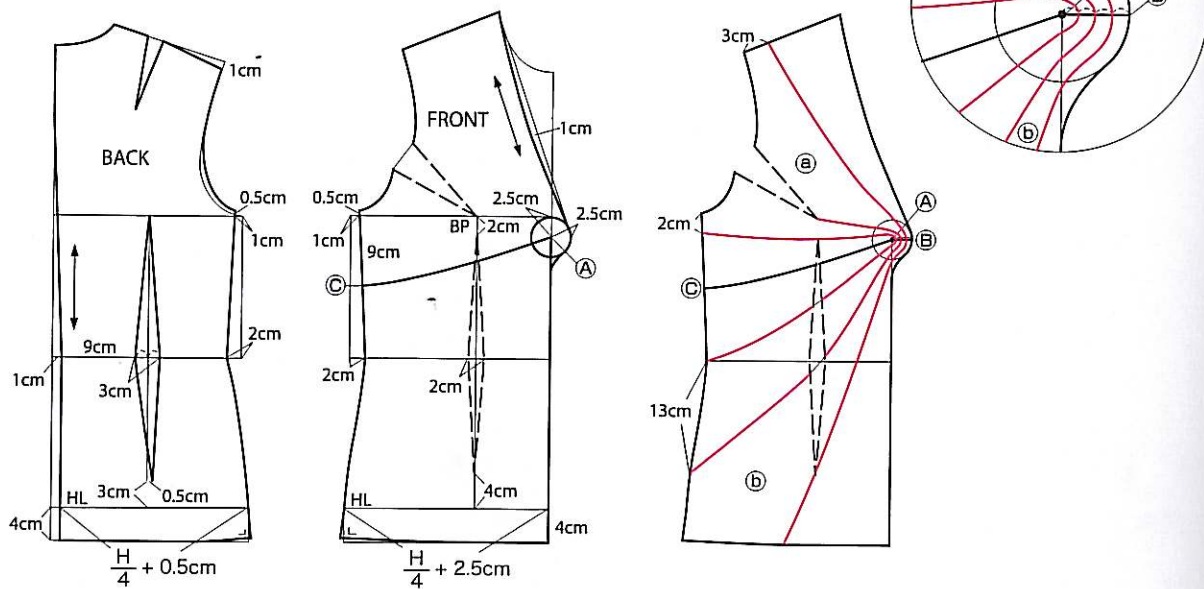

① Insert waist darts so that the bodice is fitted in the waist area. The bodice front darts are closed when cutting and opening out the draped area. The centre of the draped area is expressed on the drawing by a circle, considering the bulk created by the layers of fabric. The line connecting (A)–(C) is the design line for making the hole.

② Divide (A)–(B), the radius of the circle, into four equal sections and insert the cutting and opening out lines. Divide the pattern above and below (B)–(C) into panels (a) and (b) respectively.

Simple draped design (without twisting the fabric)

Intersect the left and right bodice panels through the hole and create the draped design. The larger the circle, the more relaxed the design will be, and conversely, the smaller the circle, the sharper the design.

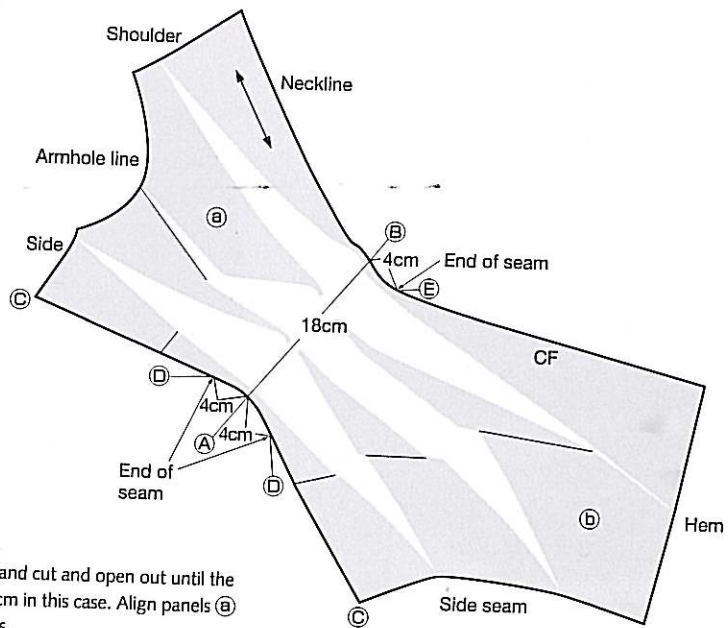

- 3 Close darts on both panels (A) and (B) and cut and open out until the distance between (A) and (B) becomes 18cm in this case. Align panels (A) and (B) and draw smooth, continuous lines. To make the hole, decide where the seam will end and call it (D).

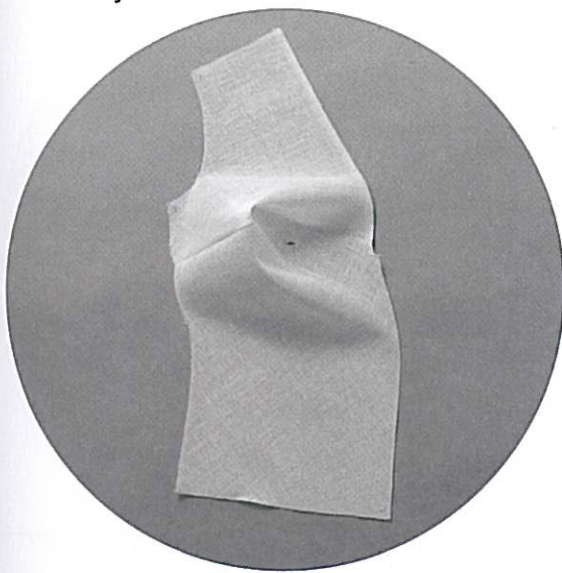

- 4 Sew together the area between (C) to (D) on one bodice panel.



- 5 Insert the other bodice panel into the hole you have made and sew from (C) to (D). Sew the centre front from (E), the end of the seam, to the hem.

Complex draped design (adding one twist to the fabric)

The intersecting of the left and right bodice panels is the same as on the simple draped design bodice, but the adding of one twist keeps the fabric in place, thereby showing the modulations in the design. Remember that the underside of the fabric will appear at the front.

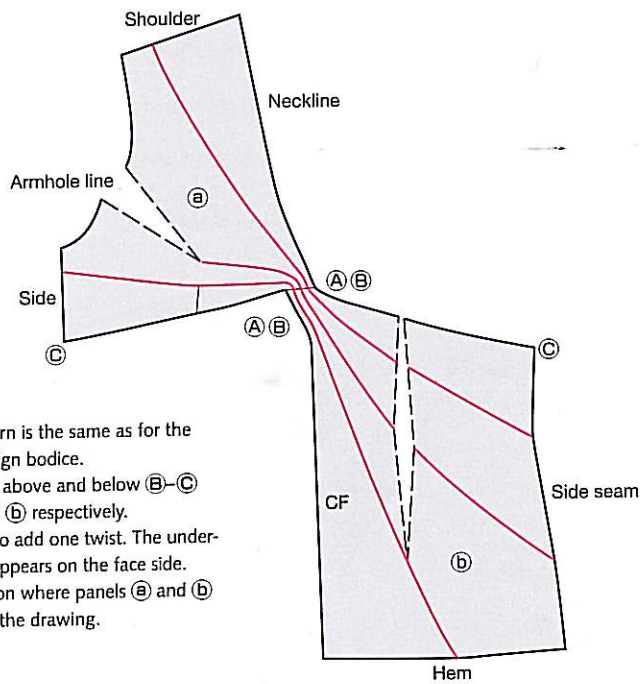

- 1 The basic pattern is the same as for the simple draped design bodice. Divide the pattern above and below (B)-C into panels (a) and (b) respectively. Reverse panel (b) to add one twist. The underside of the fabric appears on the face side. Change the position where panels (a) and (b) meet as shown in the drawing.

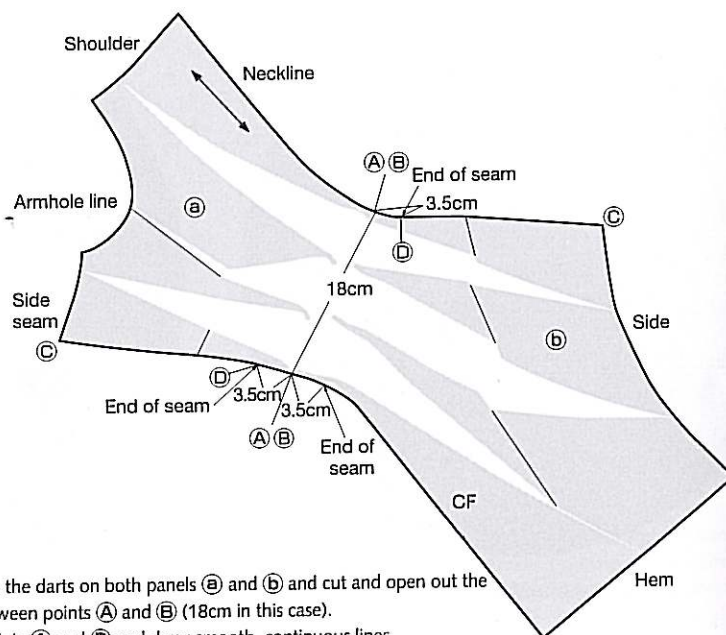

- 2 Close the darts on both panels (a) and (b) and cut and open out the area between points (A) and (B) (18cm in this case). Align points (A) and (B) and draw smooth, continuous lines. To make the hole, decide where the seam will end and call it (D).

fabric)

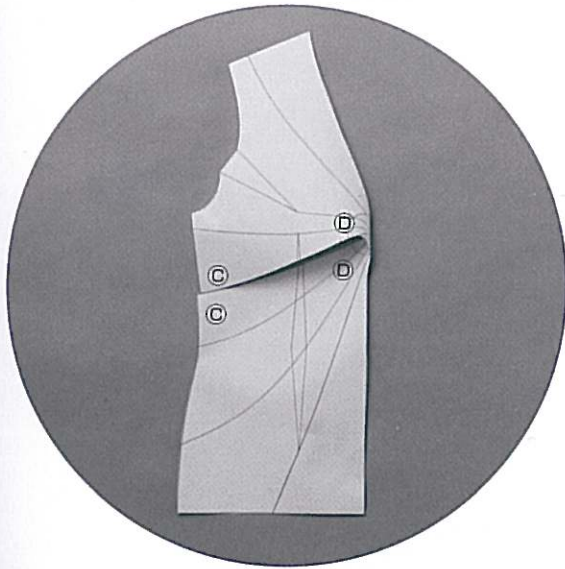

3 Where the pattern has been reversed.

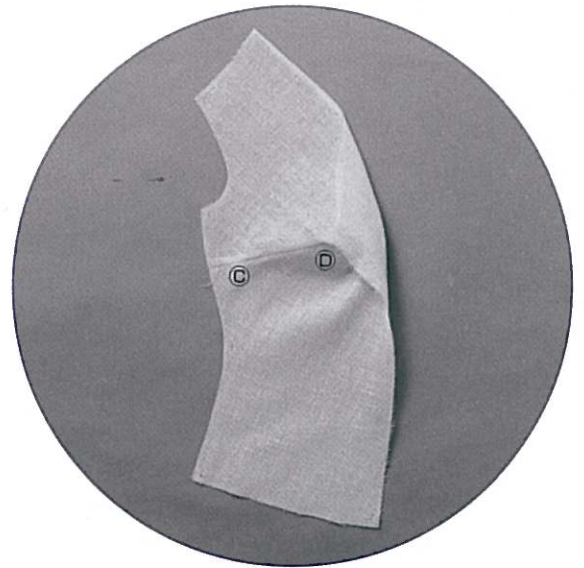

4 Reverse one half of the bodice and sew between C and D.

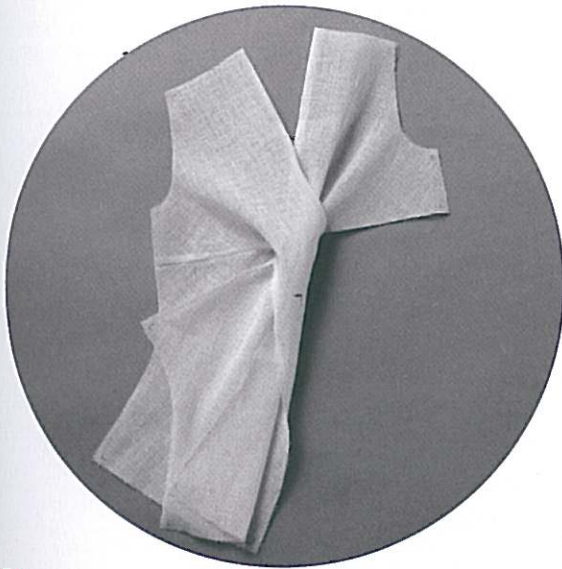

5 Insert the other half of the bodice into the hole and twist.

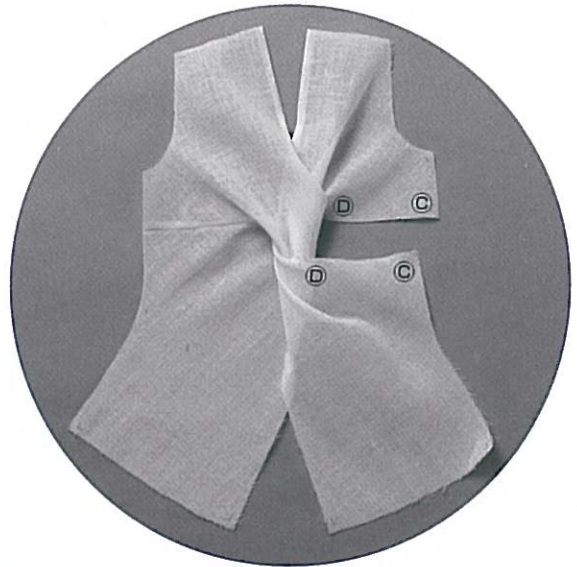

6 Sew from C to D on the other half of the bodice. Sew the centre front and from the seam end to the hem. Because of the bulk of the fabric, make the hole somewhat large and adjust after assembling.



Page 53: Dress with a draped design

A dress made from silk crêpe for more formal occasions.

The draped design around the chest is created with a technique that does not involve twisting and maximizes the soft, billowy fabric.

5cm

0.5cm

End of opening

65cm

①
ne
fr
pa
lin

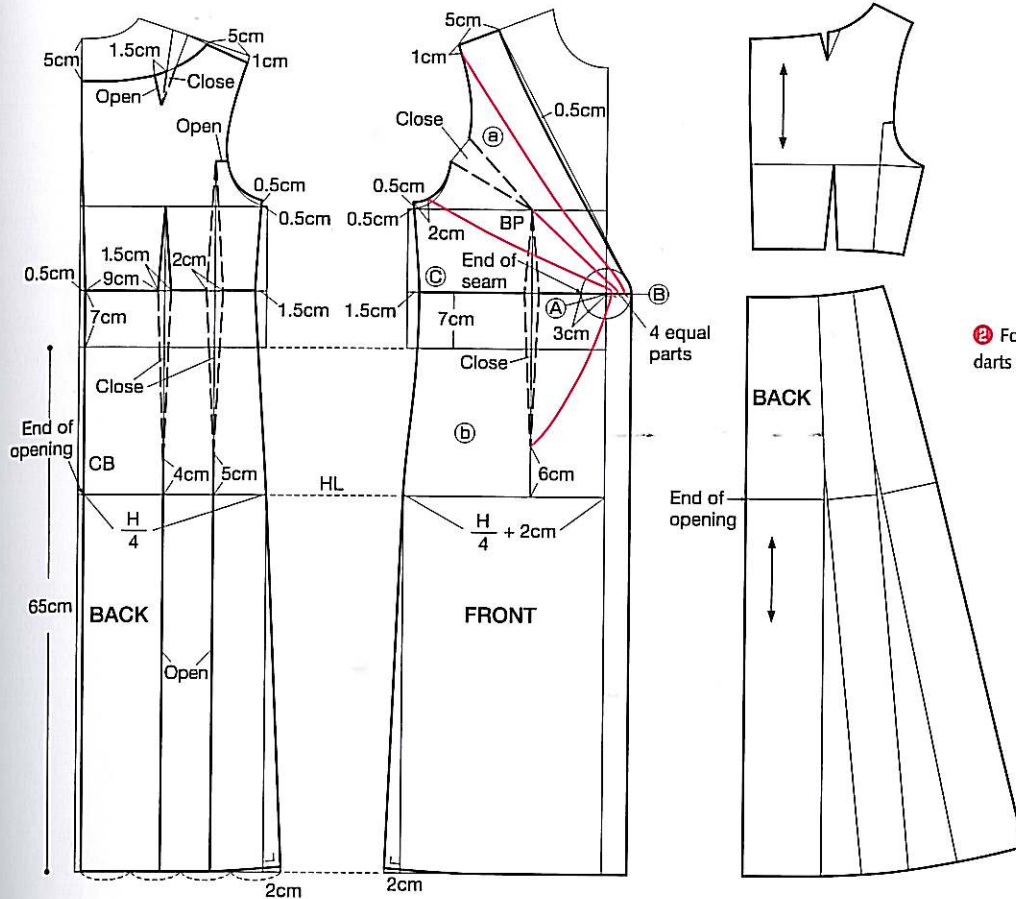

② For the bodice back, close the darts and insert a little flare.

① Because the neckline is wide, move the shoulder darts to the neckline. Divide the radius of the circle for the drape on the bodice front into four equal sections and draw cutting and opening lines on panel (a). For the skirt pattern (b), draw just one cutting and opening line facing the end of the darts.

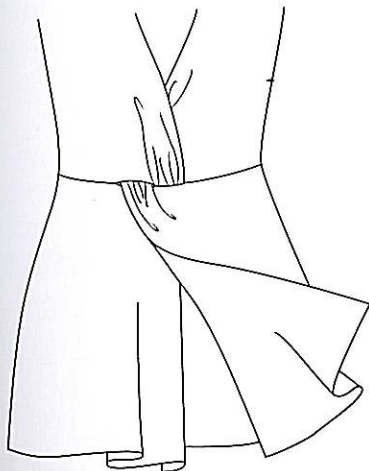

③ On the bodice front, divide the pattern on either side of (B)-(C) into panels (a) and (b). Close the darts on (a) and cut and open out. Then close the darts on (b) and open out the centre front horizontally until aligned with (A) and (B) as shown in the drawing.

Sew from (C) up to the end of the seam, cross over the other half into the hole you have made and sew this also from (C) up to the end of the seam. The centre front of the skirt is a vent and therefore not sewn. If the opening bothers you, sew it down at the back.

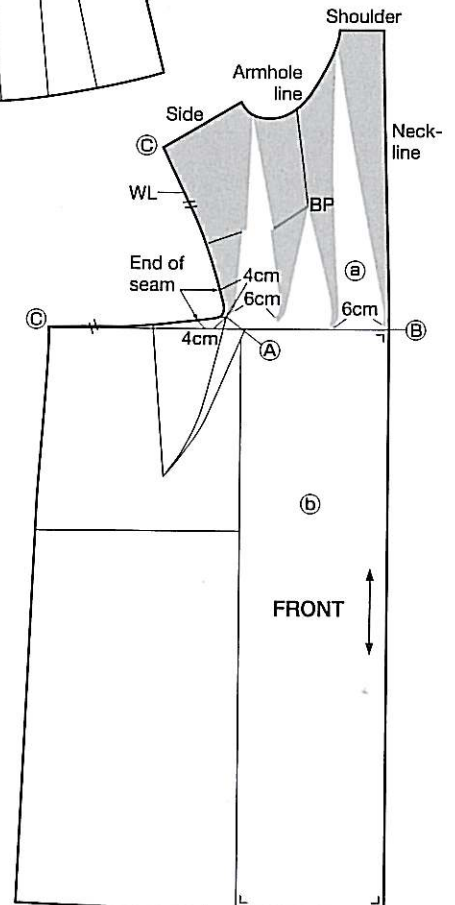

The twist (*nejiri*)

When you twist a fabric it becomes narrower and shorter, and when you release it, it returns to normal. In a different way from a garment that has a furrowed drape produced by techniques such as changing the position of the left and right sleeves, this pattern has been manipulated so that the fabric is twisted round and round like a spiral.



- Theoretically speaking, when 'a' is twisted, measurement • becomes shorter. However, as the fabric will look like that in the drawing on the right, the measurement will, in reality, be even shorter.
- As the fabric will attempt to release the twist, reduce the ease in the hips to fit precisely. A design that incorporates elastic tape or a band to keep the hemline in position and prevent the fabric from returning to normal, is best.
- As twisting makes the waist narrower, be careful not to reduce too much at the waist.
- As *nejiri* is not a natural form of the fabric, it will be easier if you use a fabric that has high stretchability.

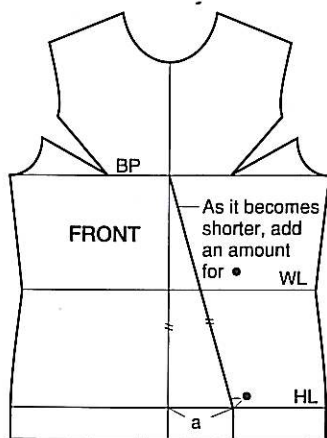
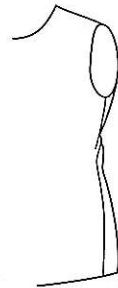

The basic bodice

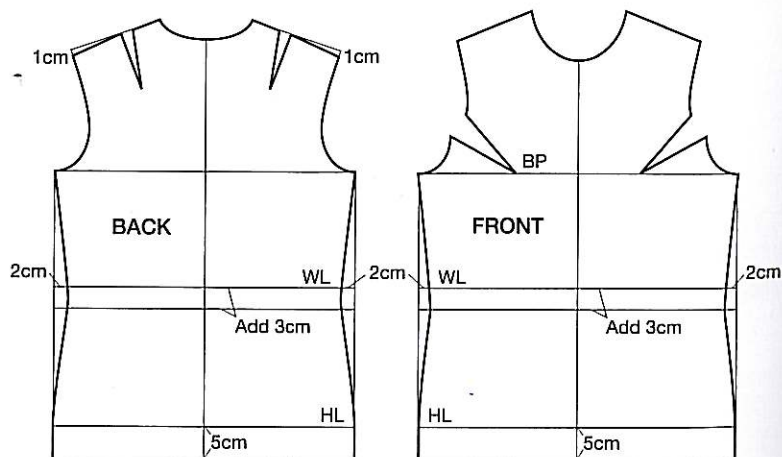

As twisting makes the garment shorter, 3cm has been added to the length. The waist has been twisted slightly.

Three *nejiri* patterns

As twisting the fabric changes the shape of the neckline and the armhole in a complex way, here the fabric has been twisted only around the waist.

Twist horizontally

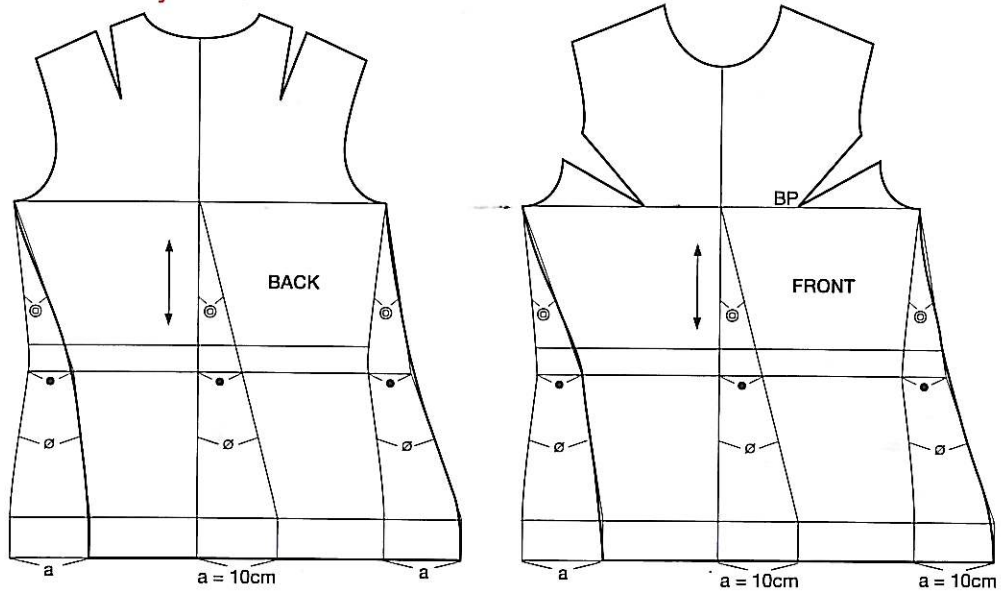

- ① Move the centre by a measurement equal to 'a' in the opposite direction of the twist you want to create in the fabric.
- ② Move both side seam lines horizontally as shown in the drawing (in this case 10cm).
- ③ Redraw the side seam lines to connect the corner of the armhole and the waist and hip area in smooth continuous lines.

Twist perpendicularly

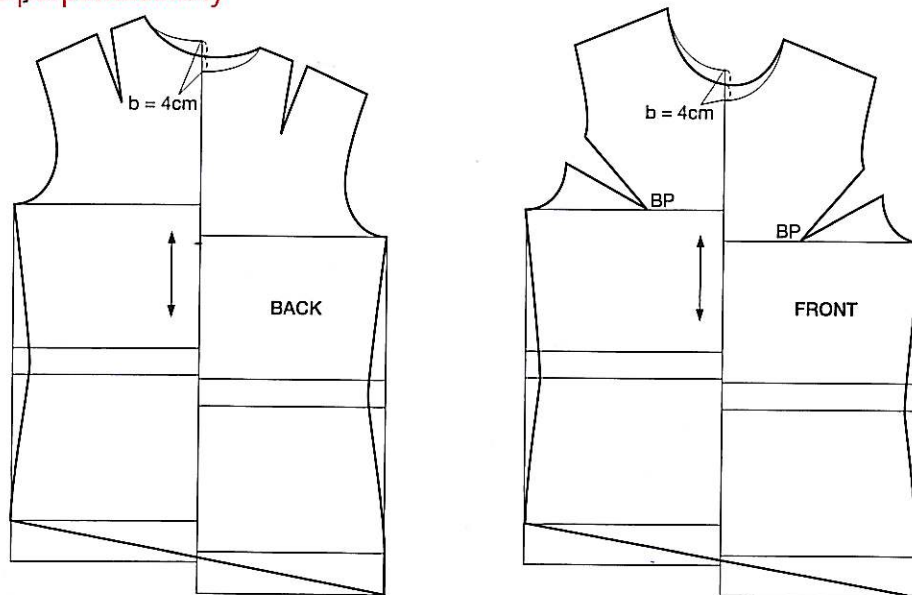

- ① Manipulate the centre front and centre back on the pattern by a measurement equal to 'b' (in this case 4cm) in a vertical direction opposite to that of the twist you want to create in the fabric.
- ② Adjust the lines for the neckline and the hem.

Twist both horizontally and perpendicularly

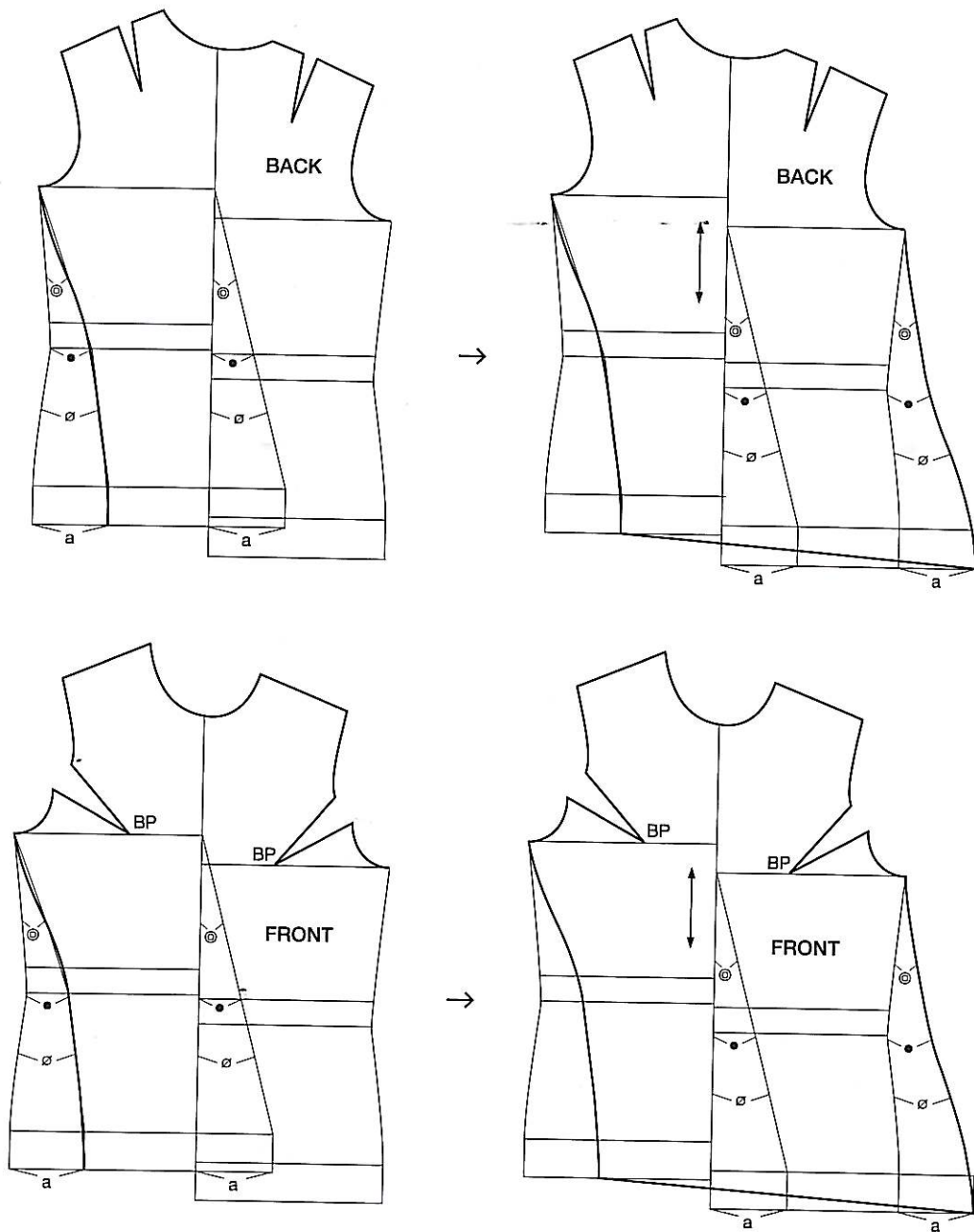

Making the fabric twist horizontally and perpendicularly at the same time is difficult, so manipulate the horizontal pattern using the pattern that has already been manipulated vertically. It is easier if you use a vertically manipulated pattern in which the hemline has not yet been adjusted. Adjust the hemline at the end.

Page 54: A *nejiri* pullover

A pullover, the pattern being a horizontal and perpendicular *nejiri*, where the movement of the fabric can clearly be seen.



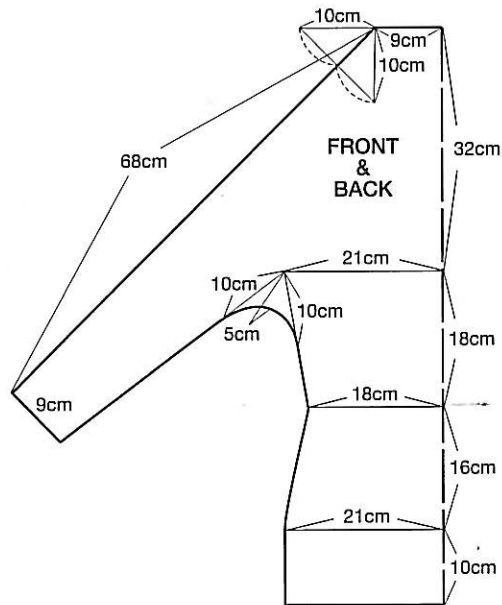

① Basic pattern

The pattern is the same for the front and the back, and the simple design where the sleeves are part of the bodice is created in a knit fabric. No ease has been added to make the garment fitted at the hip. Stretch the neckline open and check that your head fits through. If it does not, make the neck larger.

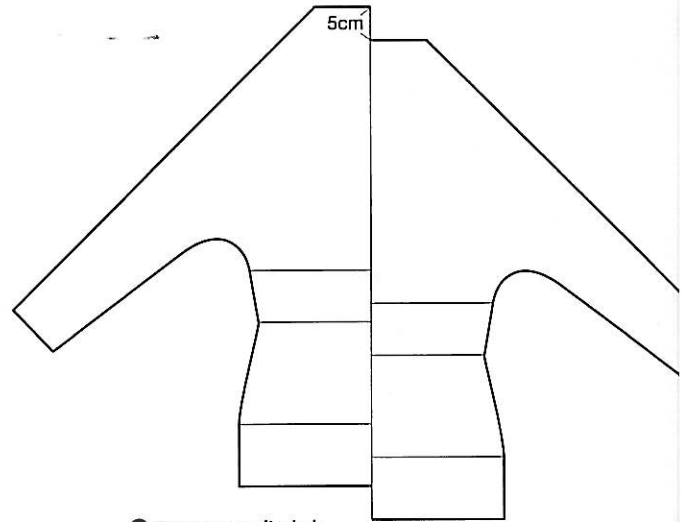

② Twist perpendicularly

Manipulate the pattern vertically in the direction opposite to that of the twist you want to create in the fabric.

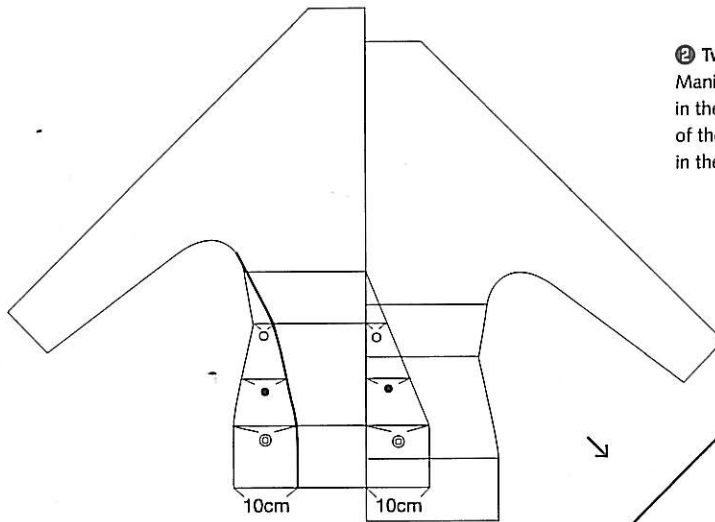

③ Twist horizontally

Manipulate the pattern in the direction opposite to that of the twist you want to create in the fabric, in the same way as for the perpendicular twist.

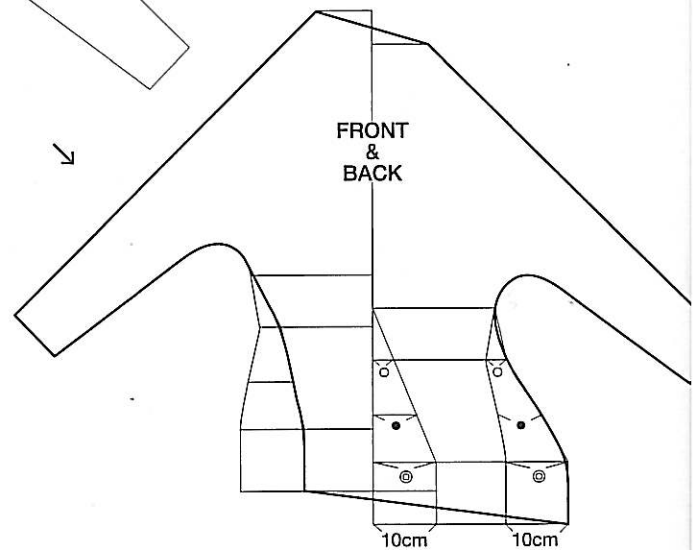

e design
: No
ch the
ot, make

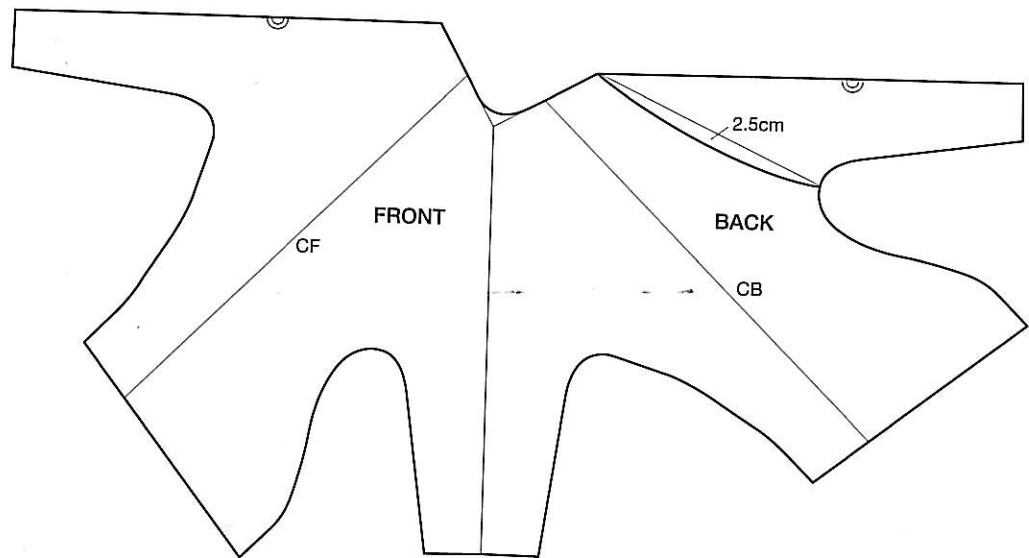

④ To create a soft effect from the shoulder to the sleeve cap, align the left and right sleeve caps as shown in the drawing. The design lines inserted into the bodice back serve as a stylish accent.

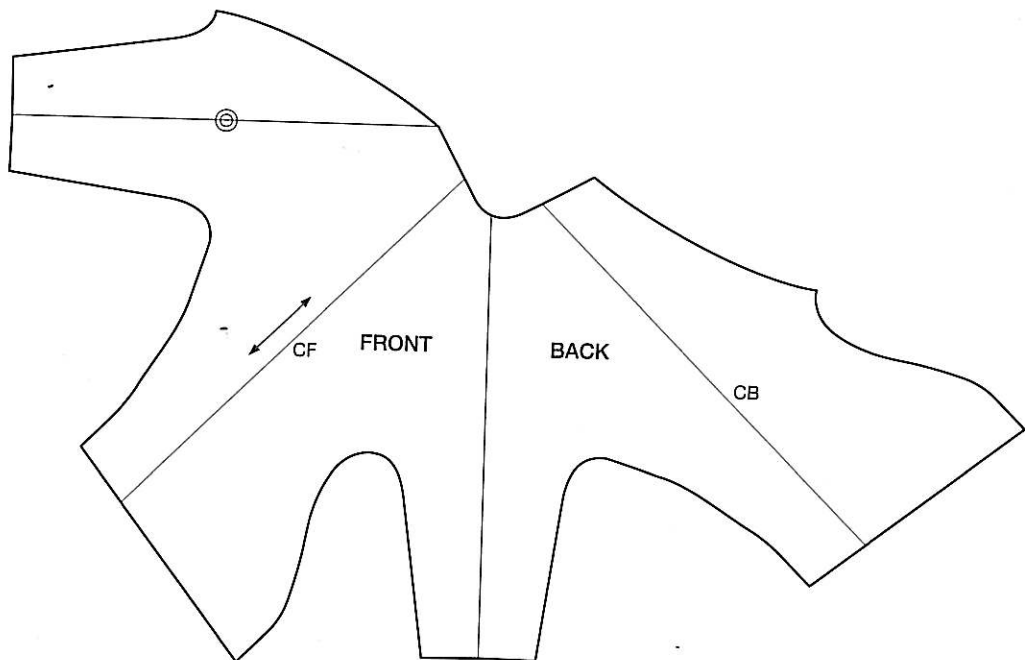

⑤ A stylish design has been created by manipulating the pattern.

Hide and seek (*kakurenbo*)

Not a flare that expands uniformly
by cutting and opening out the pattern, but a flare
that is subtly concealed on the underside of the fabric.
Making a pattern for the *kakurenbo* design
with a drawing is easier than you think.

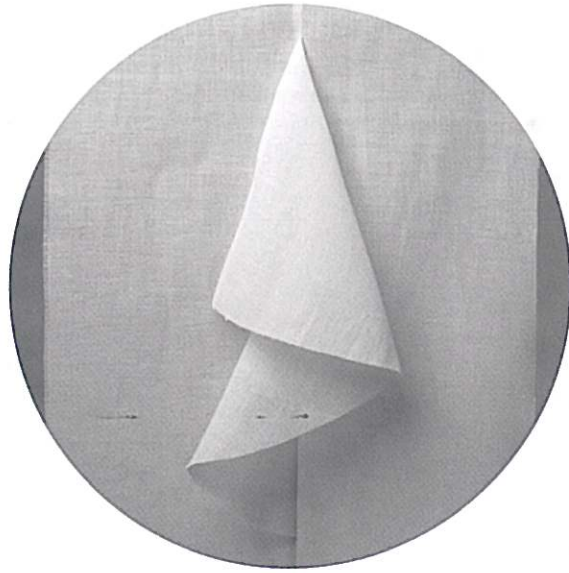

A basic jabot-style frill

A gorgeous decorative effect for the front of a blouse.
The connection between the section that is visible from the front and
the section concealed underneath is important.

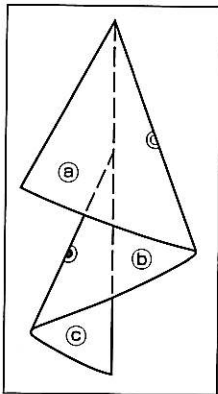

1 Make a drawing of the frill
you want to make.

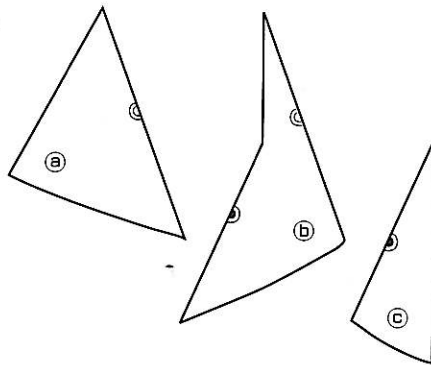

2 Separate out the various parts.

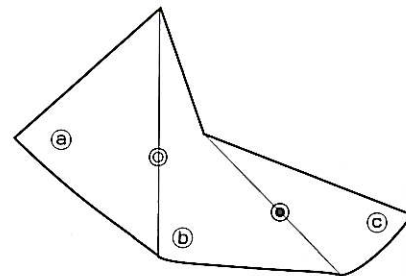

3 Attach parts a, b and c.
Reverse b before attaching or the back side of the
garment will be on top.

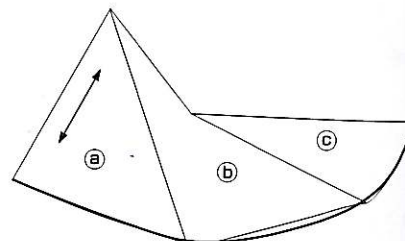

4 Smoothly adjust the line that will become the
edge of the frill.

Flare concealed in a curve

This design makes you wonder how the flare has been concealed. The folded and layered look that has so much depth is structurally beautiful and exciting. With that idea in mind, I began by drawing some complex curves.

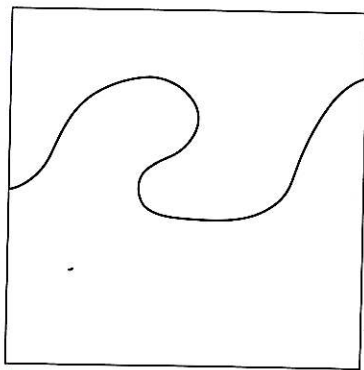
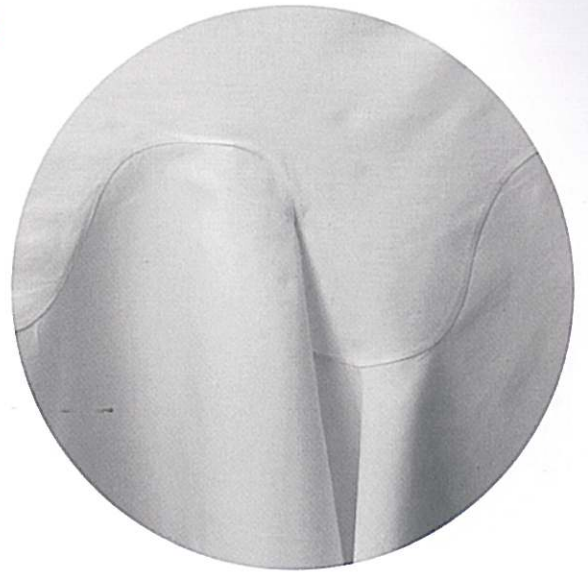

1 Draw design lines on the base.

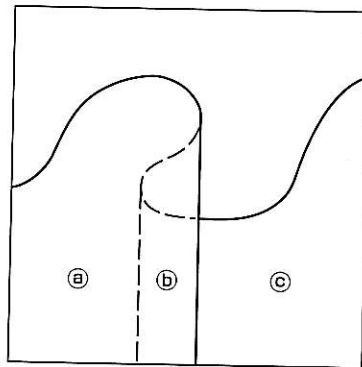

2 Insert lines in the way the frill would fall.

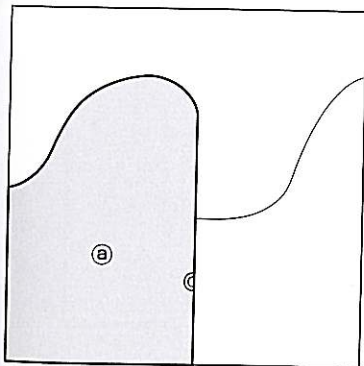

3 Separate out the various parts.

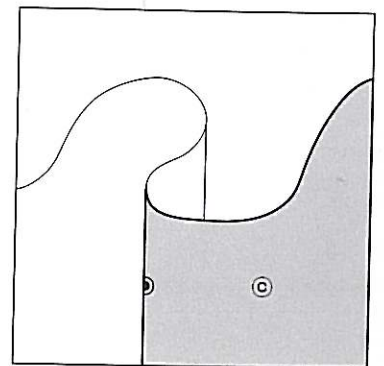
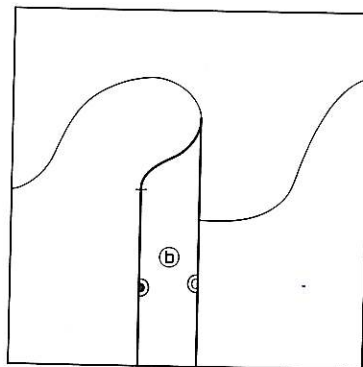

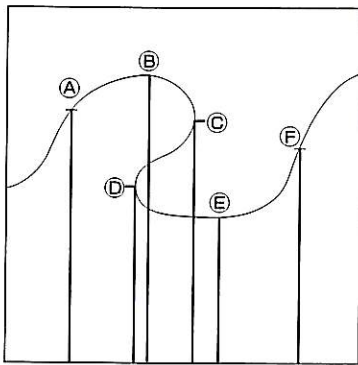

4 Return to 2 and mark the flare points (points from which the flare is going to appear) in the places you want to insert the flare. The line that descends perpendicularly from the flare points becomes the cutting and opening out lines for the flare.

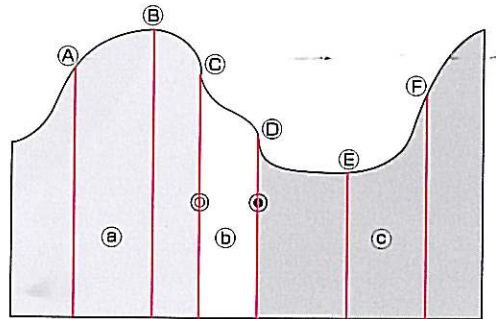

5 Align the various parts. Reverse (D) before aligning or the back side of the fabric will be on top.

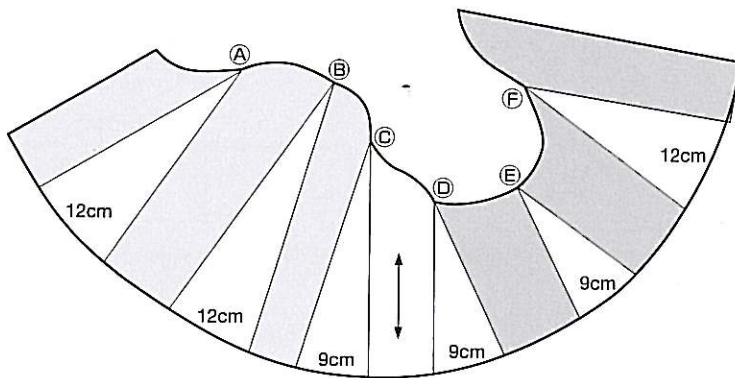
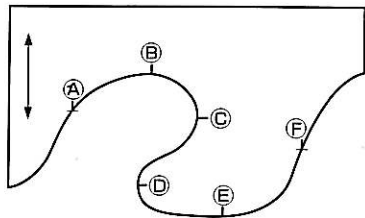

6 Cut and open out and redraw the flared hemline.



Page 55: A pinafore with *kakurenbo* design

The complex curves of the flare design lines were incorporated into the waistline of a baby doll-style pinafore made from a soft woollen georgette that neatly expresses the concealed flare.

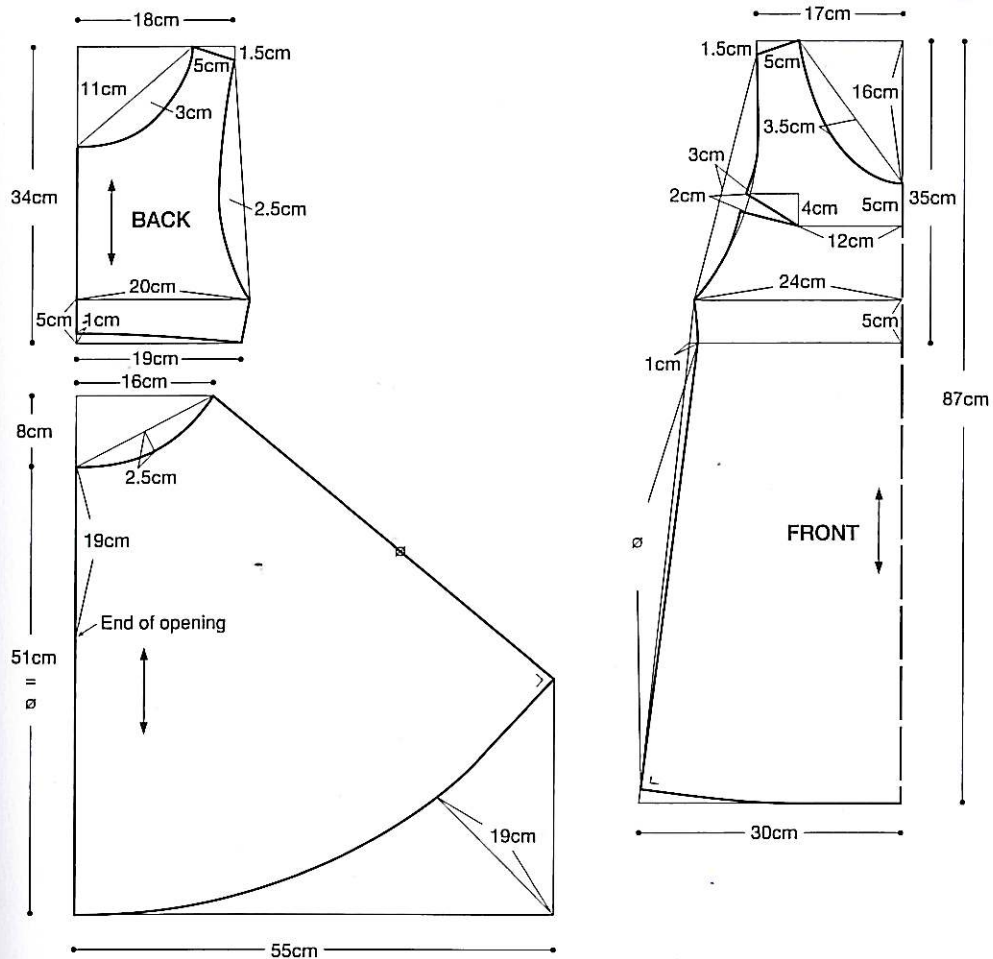

① Draft a pattern for the pinafore.

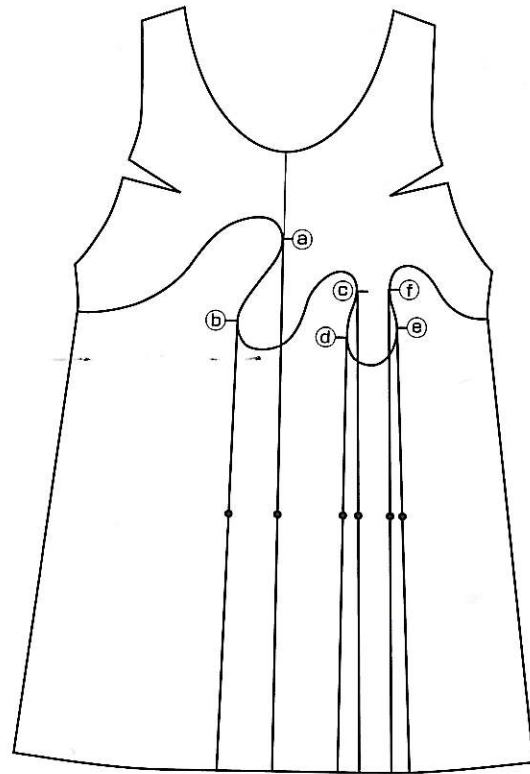
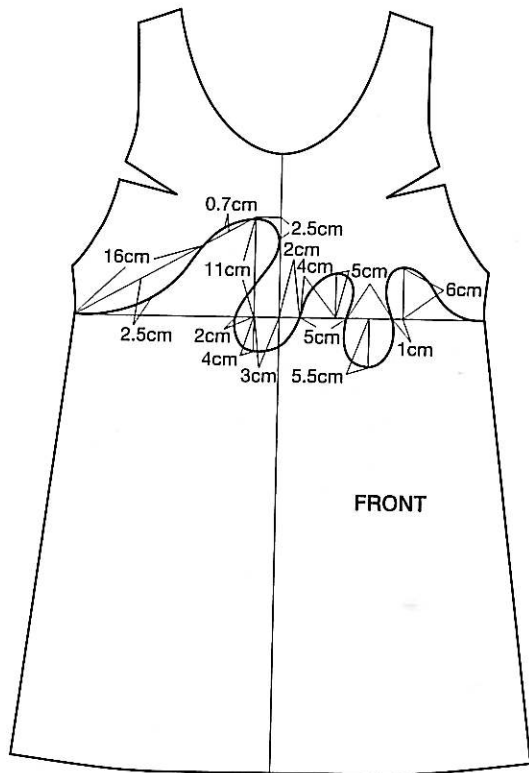

2 Draw the curved design lines on the bodice front. Find a balance that sets off the concealed section.

3 Insert alignment markings and cutting and opening out lines (•) into the concealed section. The alignment markings will become flare points.

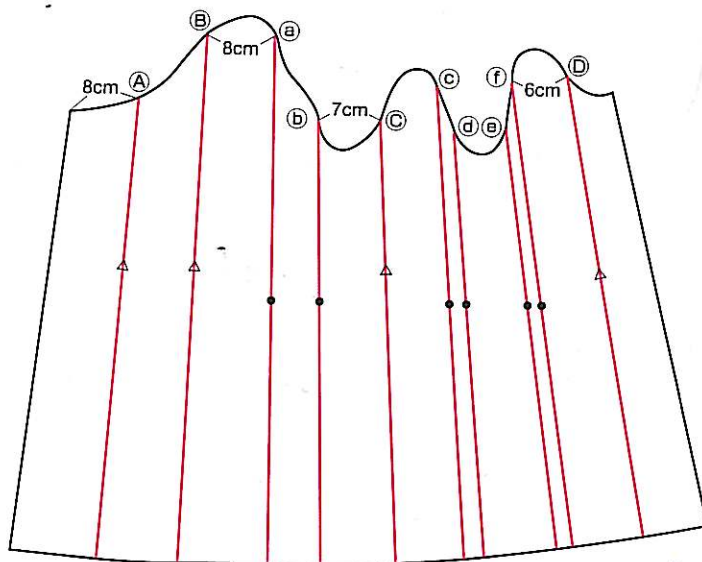

4 Reverse the concealed sections, bring them to the front, and connect. Add flare points (A-D) in a balanced way and draw the design lines for the flare (Δ).

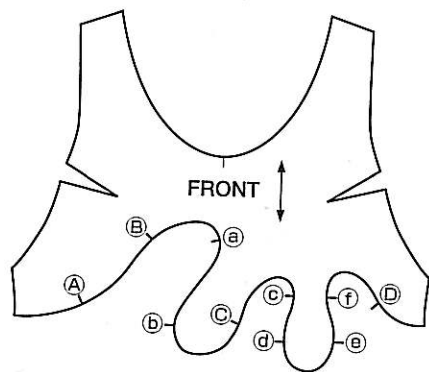

⑤ Add alignment markings A–D to the bodice to serve as markings when sewing the design lines.

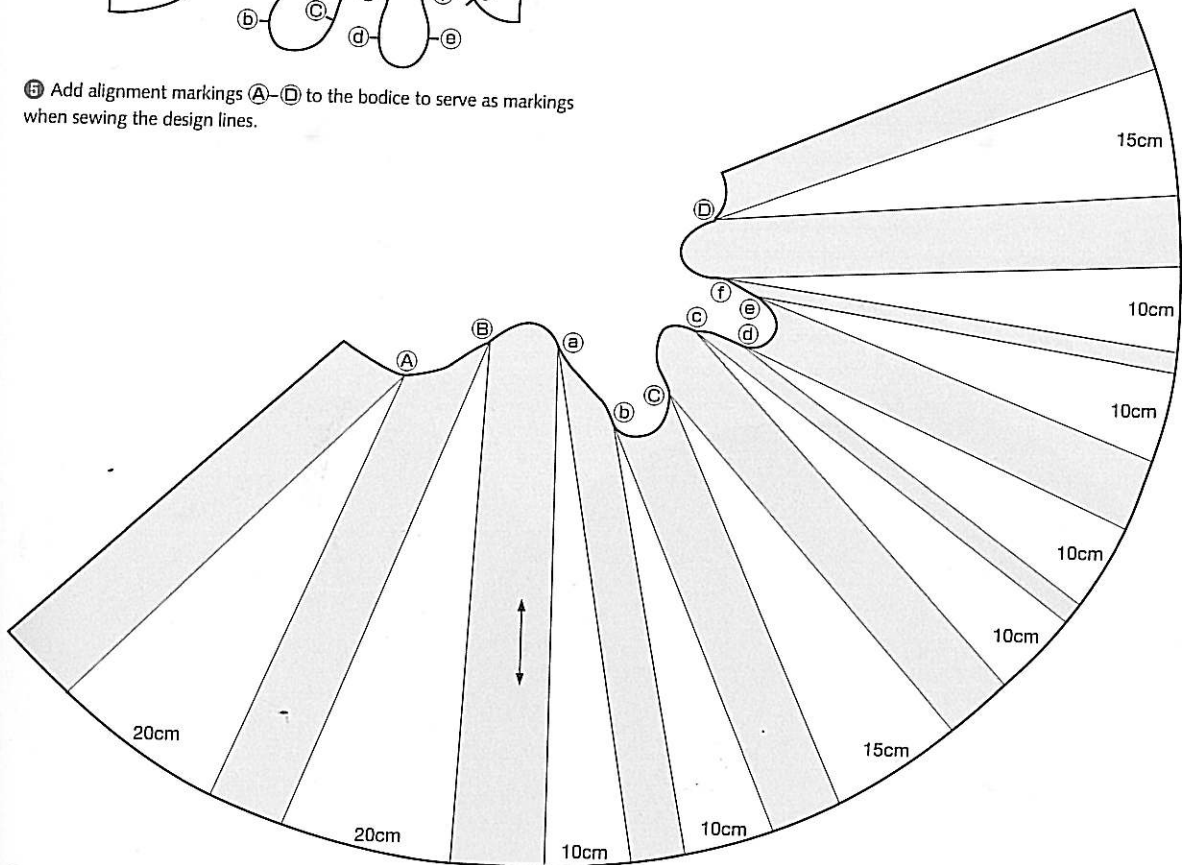

⑥ Cut and open out the amount for the flare.

Interwoven design

In this technique you gather the fabric and mold it as if it were being woven.

I decided to see if I could produce a pattern from the complex beauty created by layers of fabric woven together that I had once seen in a fashion magazine.

If the fabric on the left and the right are of different colors, the way in which the fabric intersects can be seen more clearly.

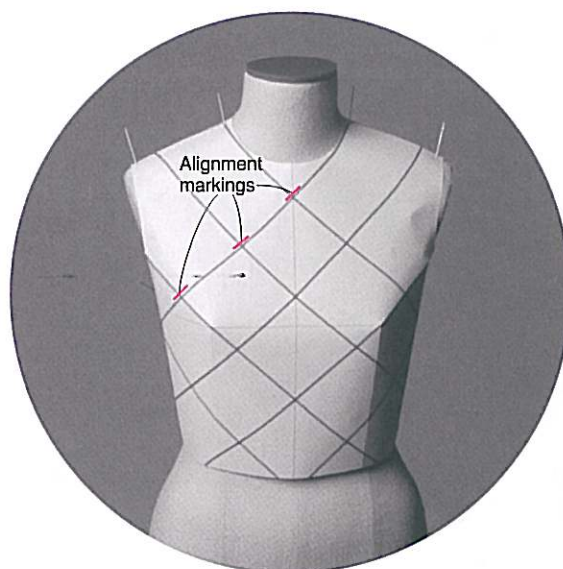

① Assemble the paper sloper (block) on the dress form and draw lines symmetrically. As shown in the drawing, make alignment markings in places where the lines intersect.



(Face side of the fabric)

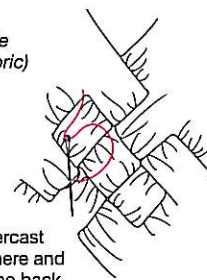

Make overcast stitches here and there in the back

Because this design contains few seam allowances, the fabric frays easily and it is difficult to make the assembled pieces of fabric stay in place. You can either wear an under-dress, or you can line the garment with the same fabric as the garment. When you line the garment, it is advisable to use a base pattern that has no intersection lines, and sew the neckline and the armholes together with the outer fabric layer.



and draw lines
places where

17/17

few seam
asily and it is
ed pieces of
either wear an
the garment with
nt. When you
le to use a base
ion lines, and
nholes together

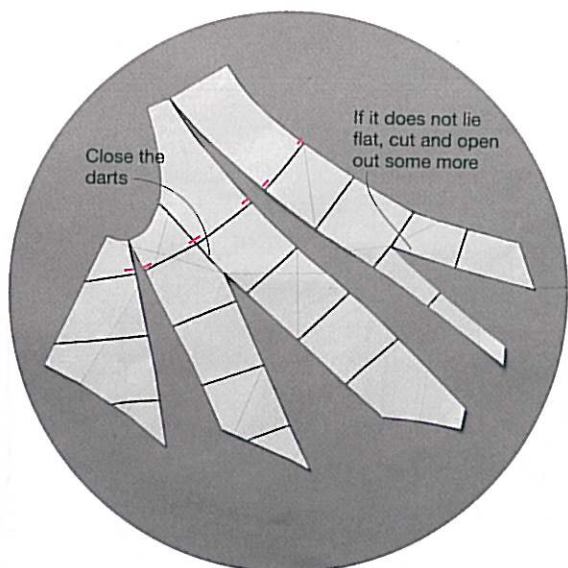

2 The parts that do not pass through the bust point refuse to lie flat even after cutting along the lines. Insert gathers in these parts, close the darts, and cut and open out. And then cut and open out the amount for the gathering again. The volume of the gathering varies according to the fabric used and according to your personal preference.

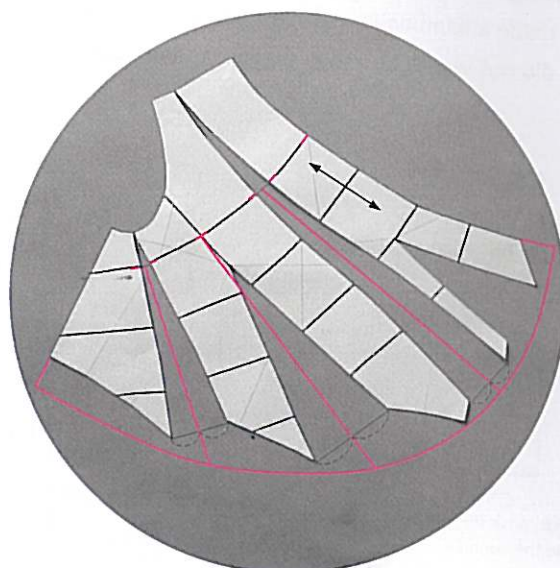

3 Cut as shown in the drawing above. Because different fabrics have different grains and some stretching may occur when you interweave the fabric pieces together, cut the fabric with some ease in the hemline and adjust it at the end.

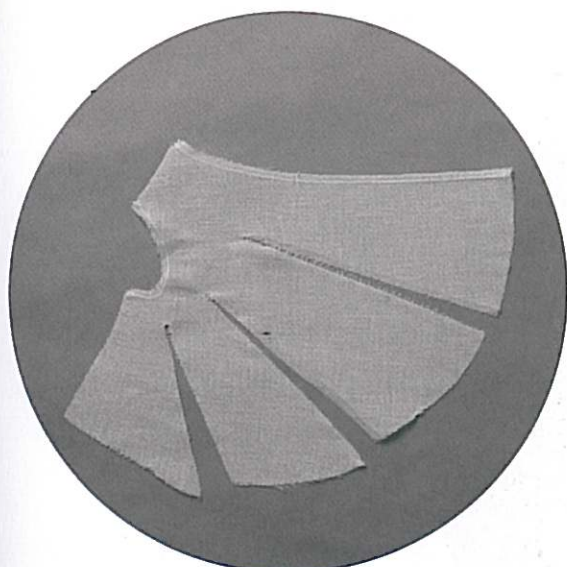

4 Be careful not to cut too deep. Make cuts into the fabric up to the alignment markings inserted in step 1.



5 Interweave the fabric pieces from the top in the same way as the lines you drew on the paper on the dress form.

Page 56: Blouse with an interwoven design

Using this technique, I created a blouse with left and right asymmetry. In cotton lawn fabric, I made a bamboo leaf shape from the points of the fabric that I cut into. I did not sew the pointed sections down, preferring them to be loose.

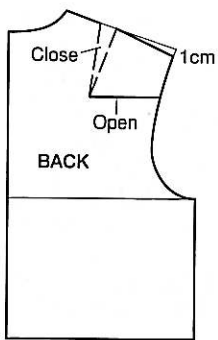

1 Move the shoulder dart to the armhole.

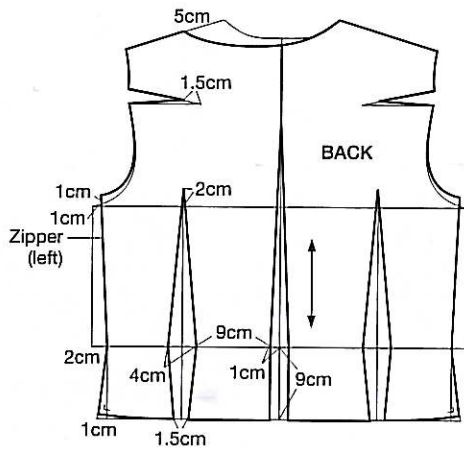

2 Draw the neckline on the bodice back with left and right asymmetry.

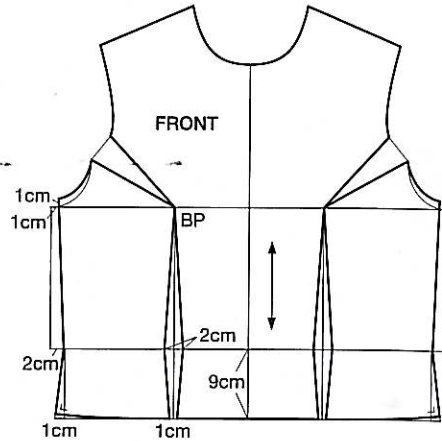

3 Draft a pattern for a fitted bodice front.



1cm

4 Dra
bodice
Insert
interse

5 Fold
from the



dice front.

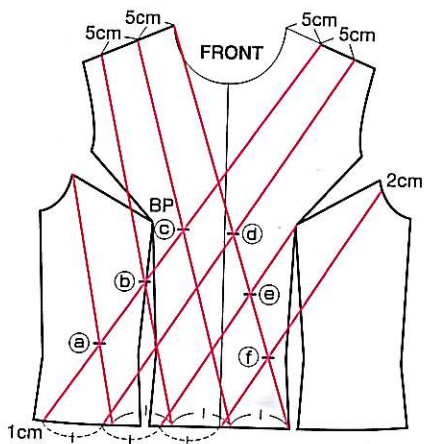

④ Draw the intersecting lines on the bodice front. Insert alignment markings (a)–(f) for the intersections into the left and right bodice.

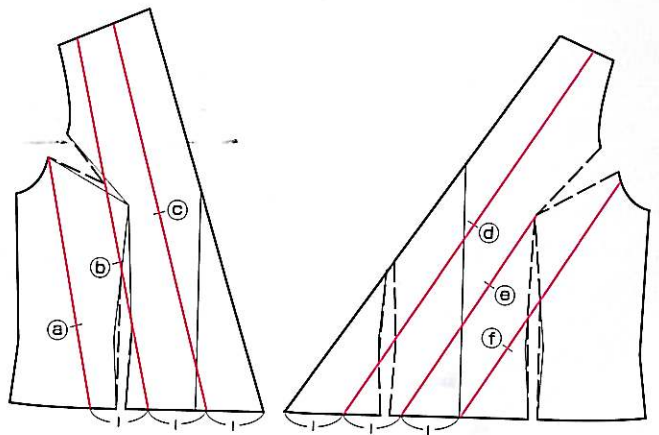

⑤ Copy the left and right bodices separately. It is easier in terms of the pattern making for the intersecting lines to pass through the BP, but where they do not, as in the right bodice front, adjust the length of the armhole dart as shown in the drawing. Here the waist darts have been closed as you can see from the drawing.

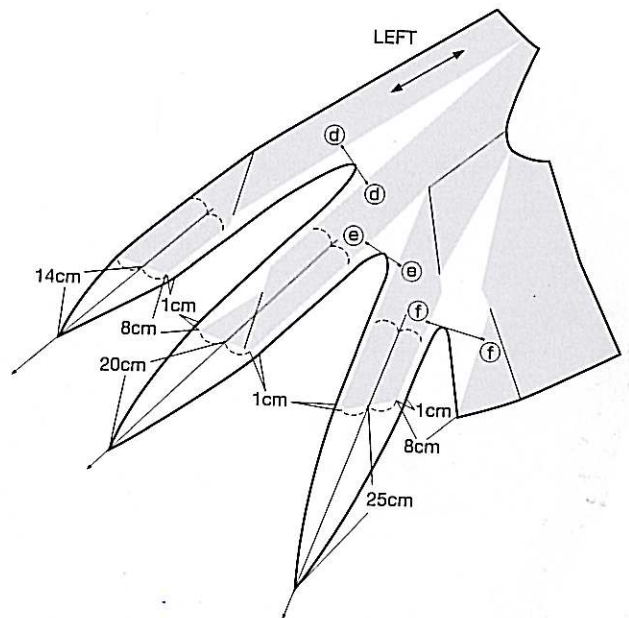
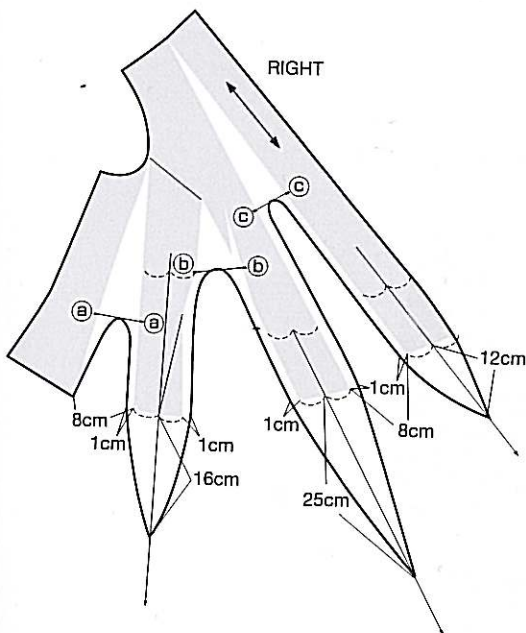

⑥ Fold the darts and cut and open out the pattern. Make the points decorative. As the fabric is transparent and extremely delicate, make a lining from the same fabric.

Bamboo shoot (*takenoko*)

Page 57: Bodice with a *takenoko* design

In this exciting technique, layers resembling the multi-layered neckline of a formal kimono are created from one piece of fabric.

They look exactly like the layers of a bamboo shoot.

The lighter and more fitted the silhouette of the bodice, the more the shading in the fabric stands out.

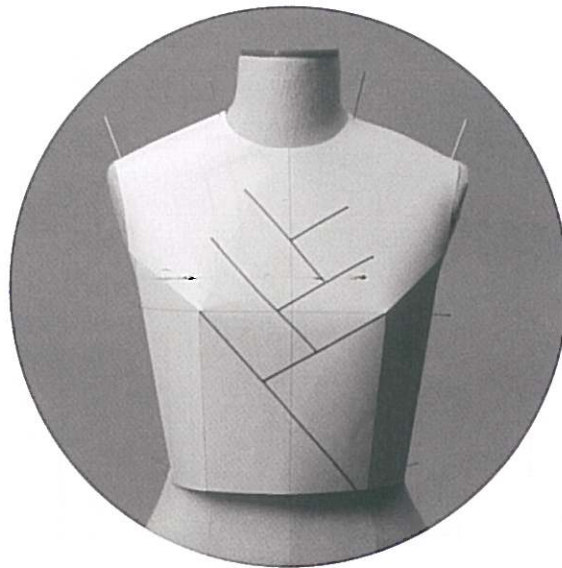

① Make a paper sloper (block) and draw tuck lines to create a design resembling a bamboo shoot.



② Cut into the fabric above the BP.



④ Cut into the fabric. About 1.5–2cm in seam allowances.

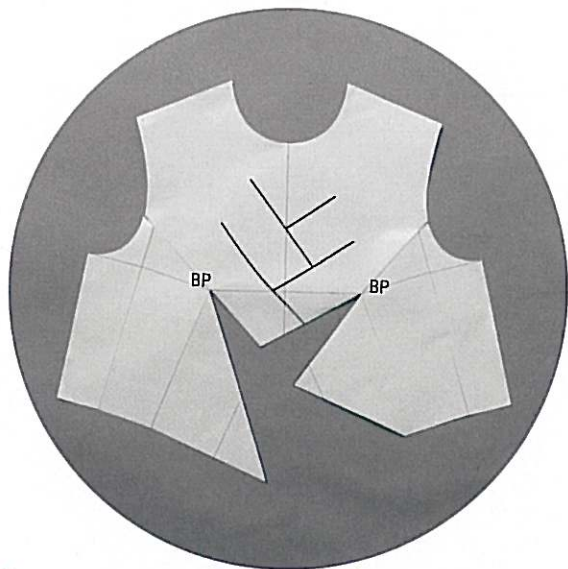

2 Cut into the tuck lines and close the darts and flatten. Do not cut above the BP.



3 Extend the lines towards the shoulder and the armhole, then cut and open out to create the amount for the tucks.

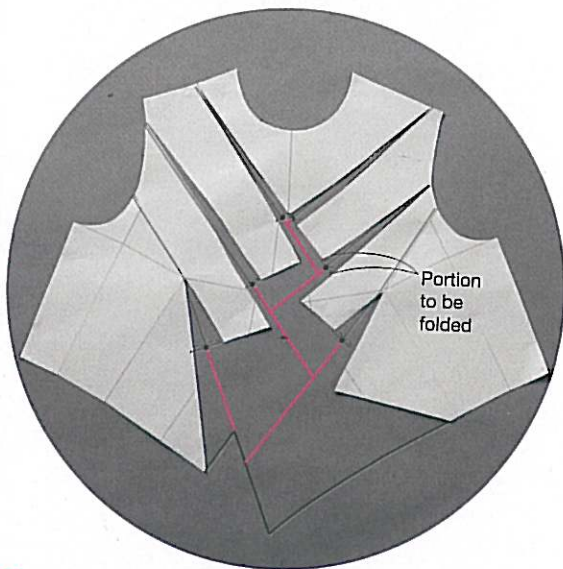

4 Cut into the fabric along the red lines. About 1.5–2cm is required to be folded considering the fraying of the seam allowances.



5 Form the tucks from the top downwards.

(Back side of the fabric)

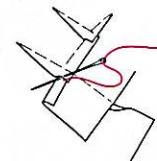

Make overcast stitches here and there only on the seam allowances.

The knot (*musubu*)

Create a classic garment merely by draping the bodice fabric in the way you want and then tying a dramatic bow.

Position the bow where you want by manipulating the pattern, and then change the width, the length or the way of tying the bow.

Clos
until

E

Clos
until

① Close
Establish
Ease is re
Draw the



Note: The c

Page 58: Knot dress

Basic pattern manipulation for a knot dress

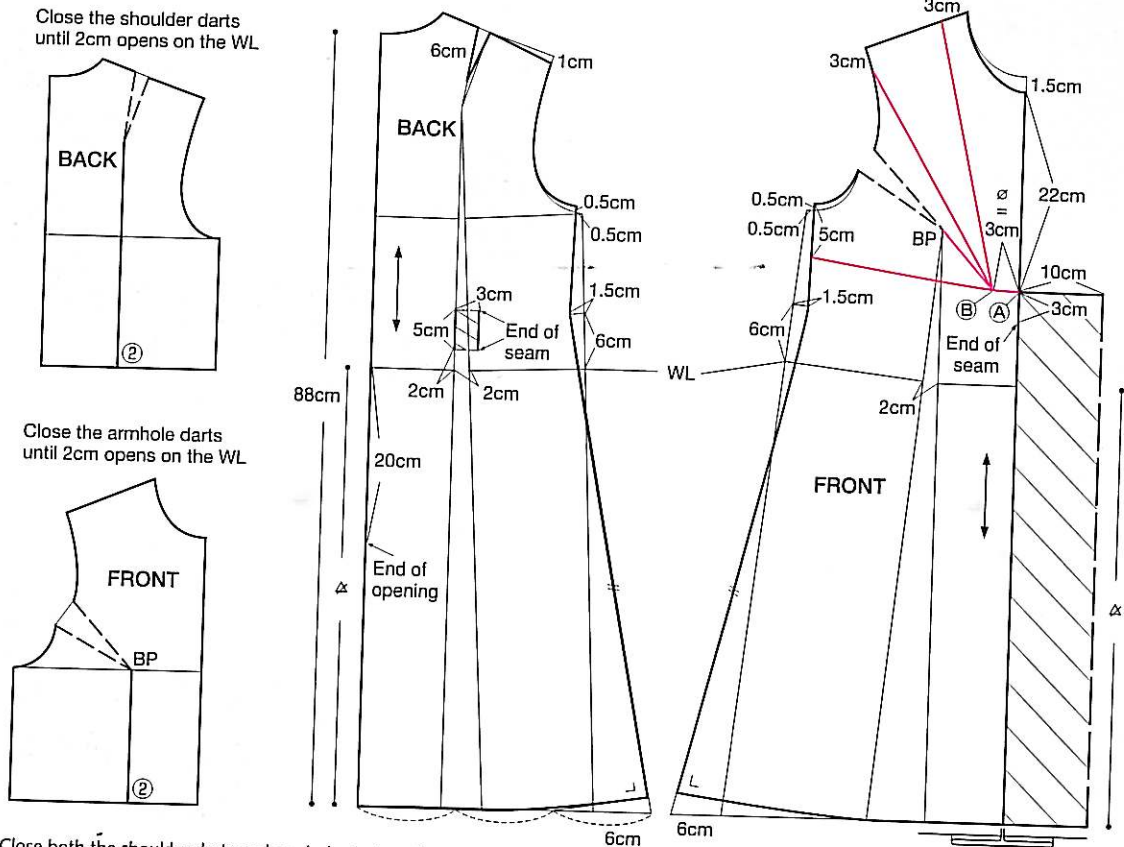

① Close both the shoulder darts and armhole darts until 2cm opens on the waistline, then make a pattern for the dress base. Establish the centre of the knot (A) in the position where you want to create the bow. Ease is required in the width of the knot to tie at (A). Measure \varnothing from (A) (3cm in this case) and from there draw cutting and opening lines. Draw the cutting and opening out lines in the position where you want to drape the bow fabric.

② The amount that has been cut and opened out becomes the drape. Decide on the amount to cut and open out according to the fabric used. Draw the pattern for the bow from where you have cut and opened out. The bulkiness of the knot is determined by drawing the curve from (B).

③ Sew the bow section into a tubular shape up to (C).

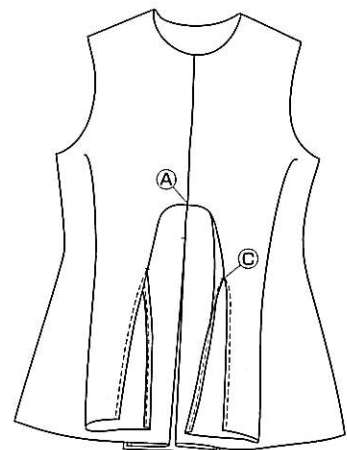
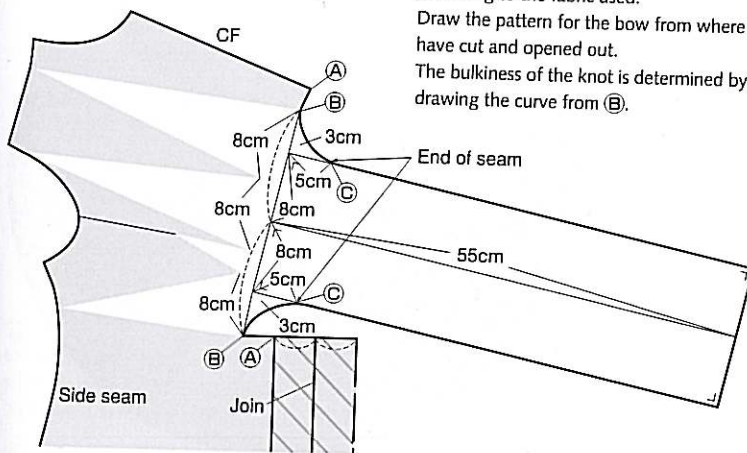

Note: The circled number at the bottom of a line indicates the number of centimetres to be opened out at that point

Page 59: Tying a bow A

A design with a different-shaped bow produced using the same pattern manipulation as used for the dress on page 87.

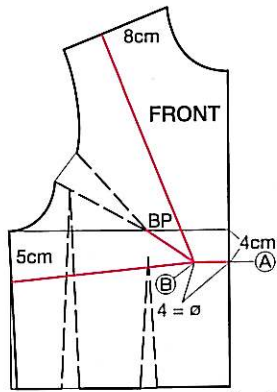

① Find the centre of the bow (A). Take the σ measurement (B) which includes added ease (4cm in this case) and from there, draw cutting and opening out lines.

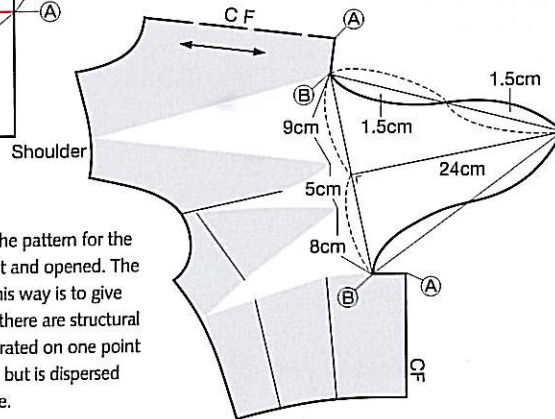

② Cut and open out. Draw the pattern for the bow from where you have cut and opened. The reason the bow is curved in this way is to give the knot some bulkiness, but there are structural reasons also. Stress is concentrated on one point if you make (B) into an angle, but is dispersed when this is made into a curve.

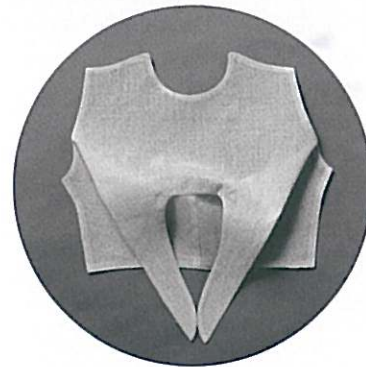

Page 59: Tying a bow B

An imaginative design in which one end of the bow is part of the bodice and the other end is part of the collar. The two ends of the bow are looped and tied together. At first sight it seems complicated, but the pattern is surprisingly simple.



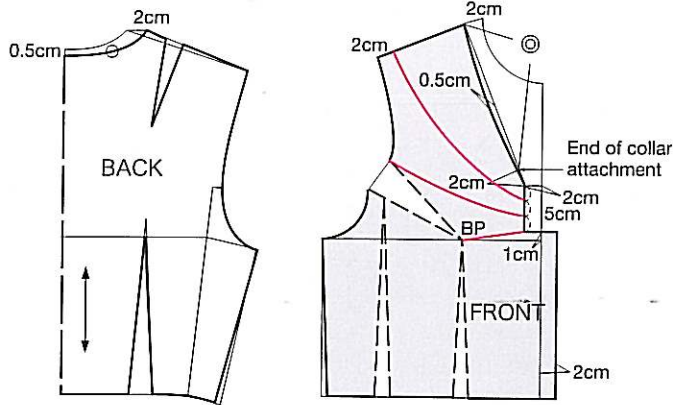

① Draft a pattern for the bodice using the sloper (block). A vertical knot is possible with this tie. Measure the width and bulkiness of the knot, and draw cutting and opening out lines.

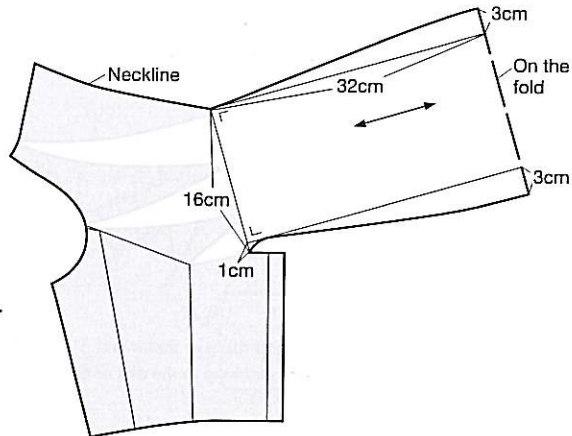

② Close the darts on the bodice front and cut and open out. Draw the pattern for the bow from where you have cut, and open out. Cut on the fold.

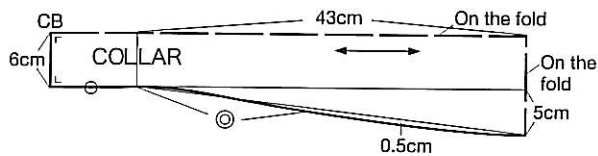

③ Pass the vertical grain of the fabric through the length of the bow to create a large, distinctive knot. A soft look is produced if you cut the fabric on the bias. If you want to insert a joint, position it inside the knot.

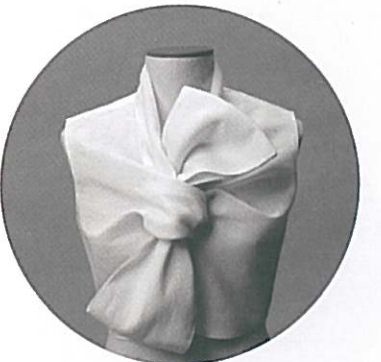
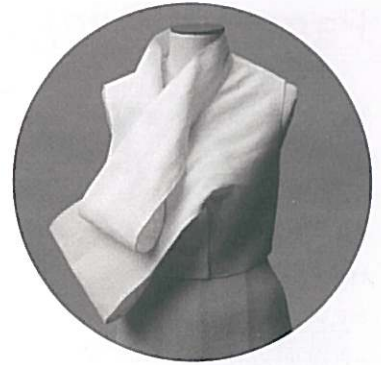

Here I have slightly changed the tying method. Other tying methods are also possible.

Page 59: Tying a bow C

Two separate bows are tied towards the right for attractive emphasis.

Here the two bows are of the same length, but one large and one small bow would also be effective.

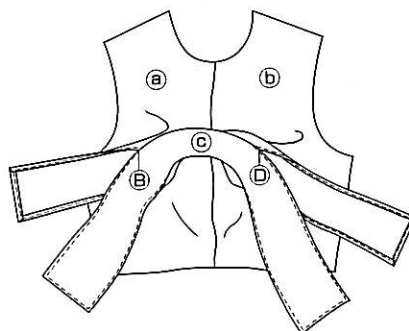

Place the second bow © on top of the bow that is part of the bodice and sew in the shape of a tube up to the end of the seam.

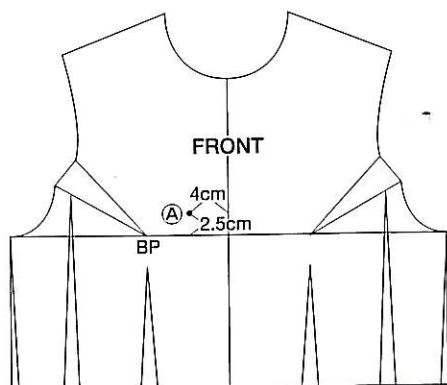

1 Find the centre of the knot (A).

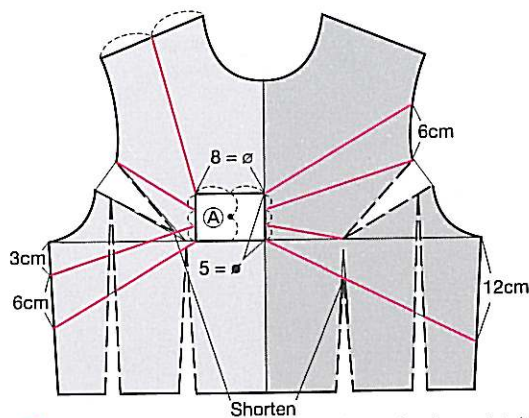

2 Measure \varnothing (the measurement to which ease has been added to the width of the knot) horizontally, and \varnothing (the measurement to which ease has been added to the thickness of the knot) vertically. Insert cut and spread lines.

Where the cut and spread lines do not pass through the end of the darts, adjust to make them end at the design lines.

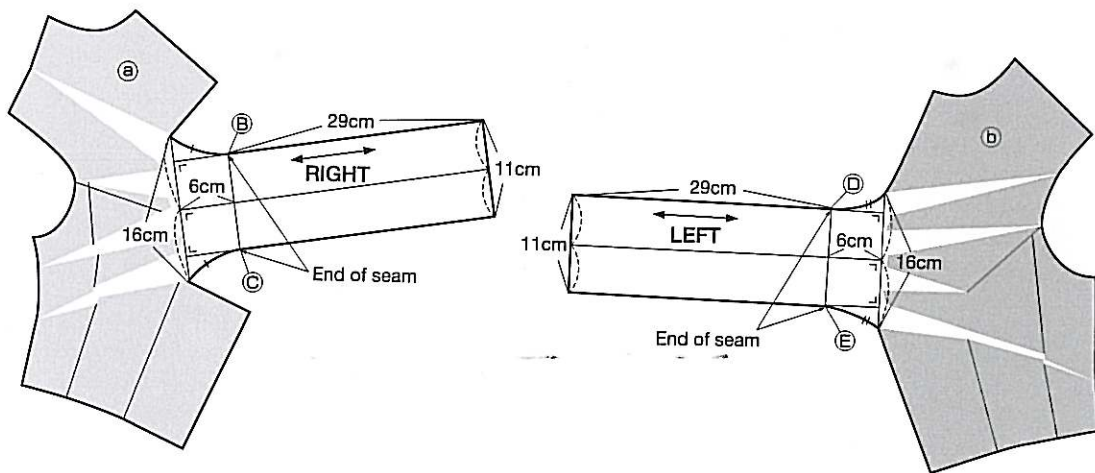

③ Close the darts on the bodice and cut and open out. From the sections that have been opened out, draw the pattern for the first bow as an extension of the bodice.

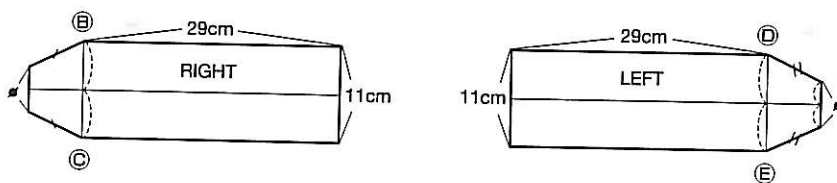

④ Draw the pattern for the second bow.

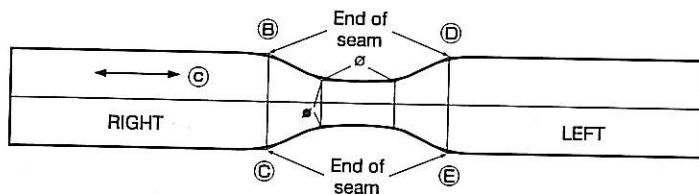

⑤ Reverse the left and right pieces of the bow in step ④; add an 8 × 5cm rectangular piece for the knot between them; align the three pieces and join with a smooth, continuous line.



Page 59: Tying a bow D

An elaborate design is achieved by passing the bow through a hole before tying. The expression of the garment changes considerably by moving the position of the hole up or down, to the side, or by changing the size of the hole. Another example of Pattern Magic!

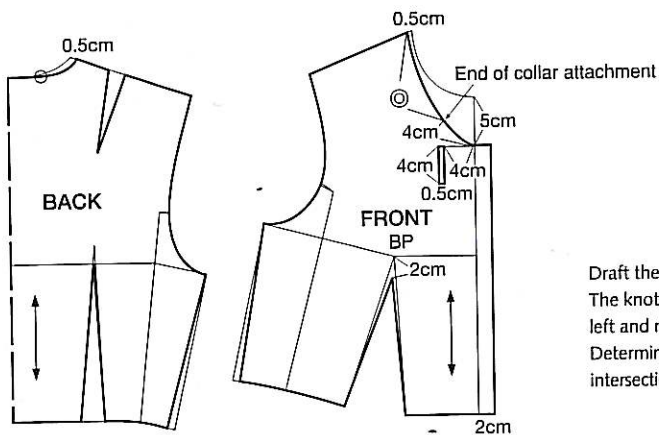
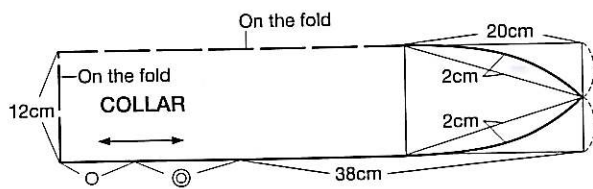

Draft the bodice pattern using a sloper (block). The knotted part of the bow that is part of the collar sits between the left and right holes. Determine the length of the bow, considering the length of the intersection, the distance between the two holes, and the size of the knot.





he
knot.



Pa
tw

A sh
colla
I cor

① U

This
the

Page 60: A collar with two distinct expressions

A shirt collar from the back and, when viewed from the front, a double collar, this offers two variations on a theme.

I combined patterns for two collars to make this intriguing design.

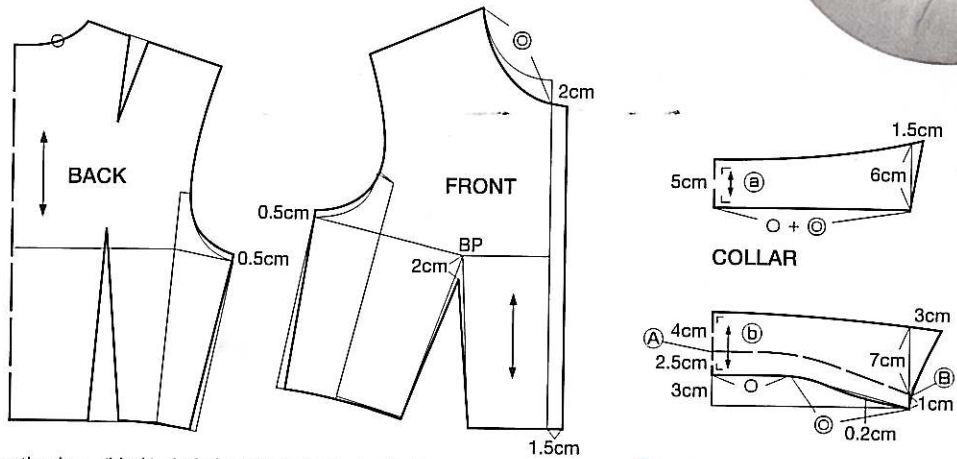
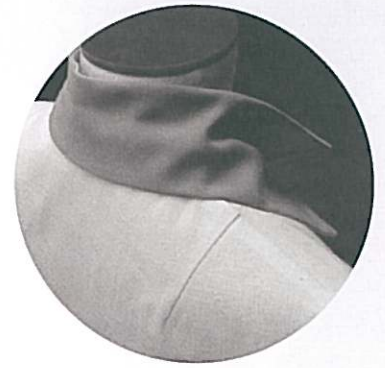

1 Using the sloper (block), draft the pattern for the bodice base.

2 Draft patterns for each of the two collars.

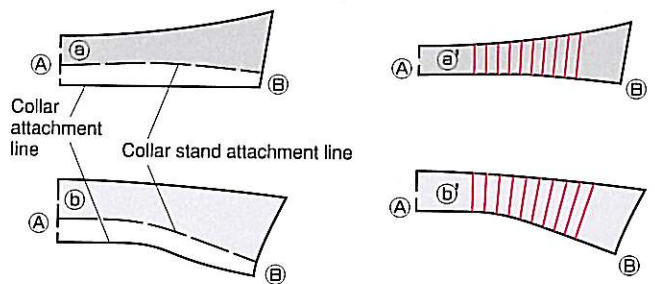
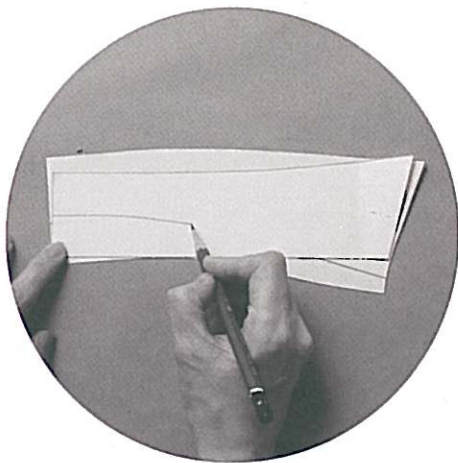

3 Align the collar attachment lines of the two collars. Copy the collar stand on collar (B) to collar (A).

4 Make patterns for collars (A) and (B) without the collar stand; then make five slits in the collar running towards the collar stand as shown in the drawing.

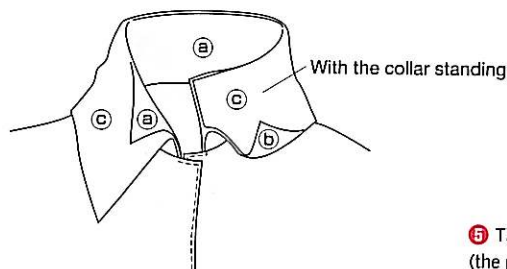

This collar is constructed from pattern pieces (a), (b), and (c) as shown in the drawing.

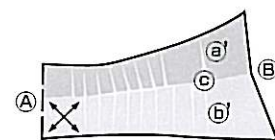

5 The pattern for (a') and (b') produced in step 4 are aligned at (A)-(B) (the pattern for (B) is face down), but as the incline is different, a gap opens between (A)-(B) and the length is not equal. Open out the slits, align (A)-(B) and call the resulting pattern (c).

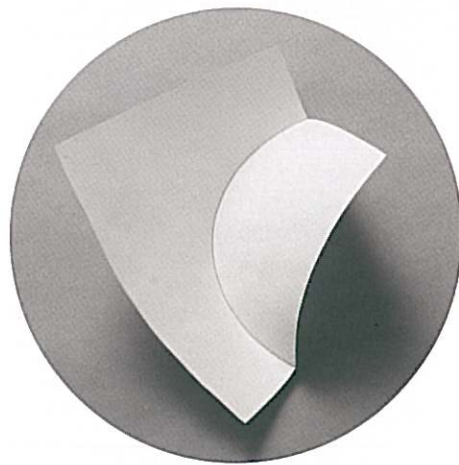
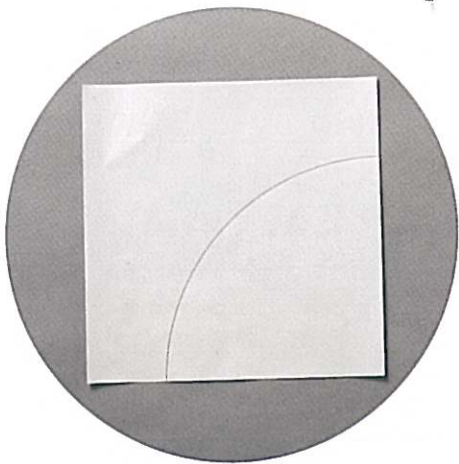
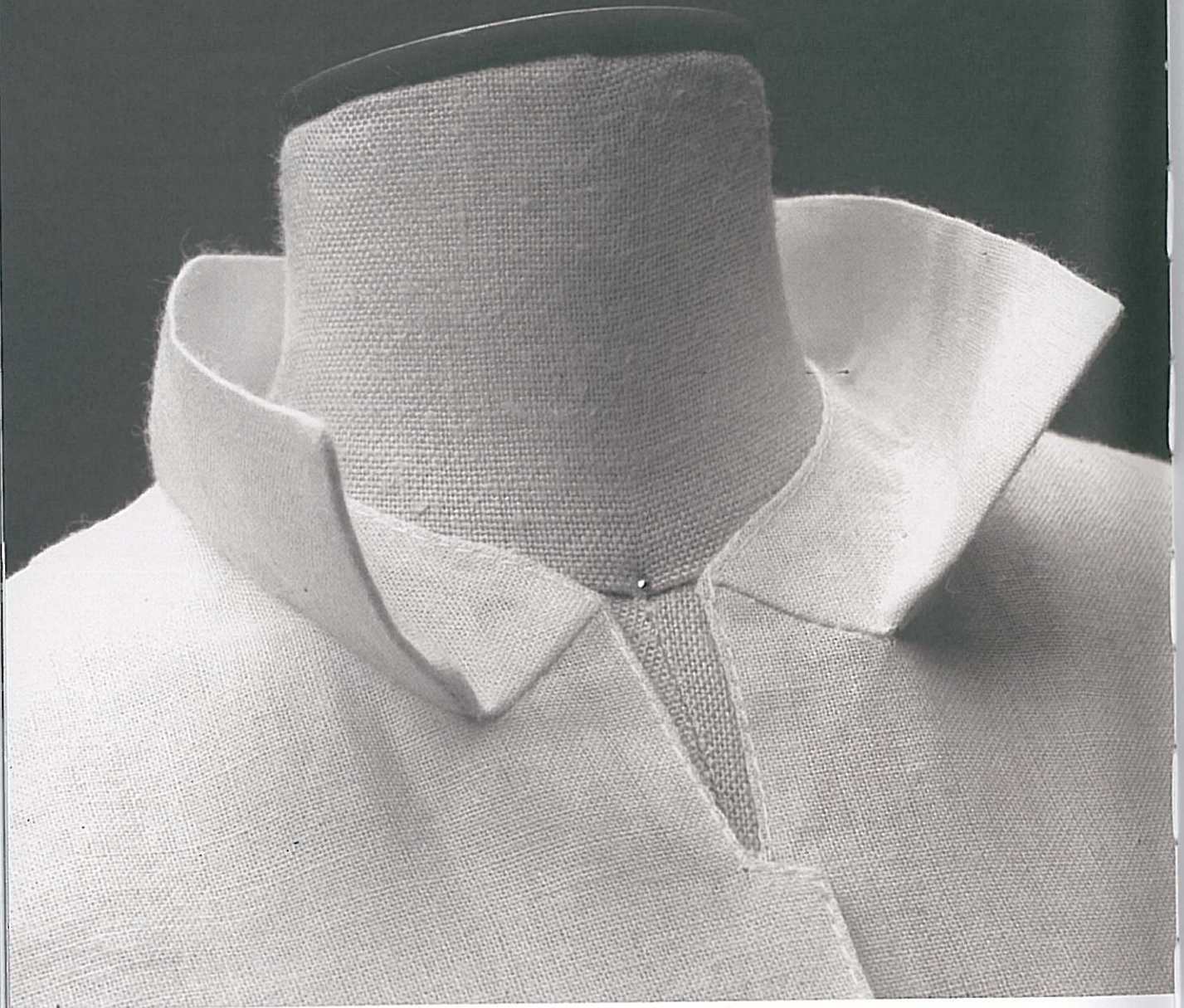

Page 60: A collar with an intriguing curve

On a sheet of paper, draw a curve and then fold along the lines of the curve. When you bend the inside of the curve slightly, the outside of the curve rises up and takes on a completely different appearance.

I applied this interesting effect to a collar.

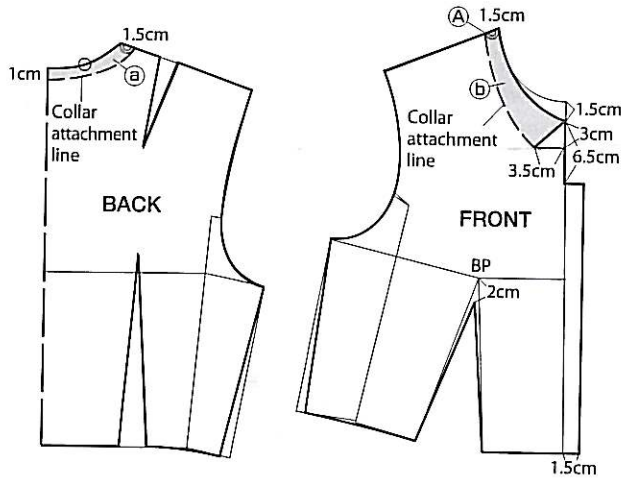

1 Using a sloper (block), draft the pattern for the bodice base. Mark the collar attachment position.

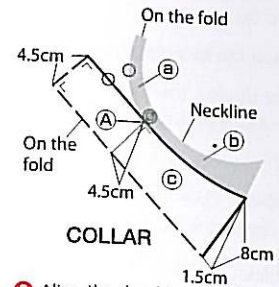
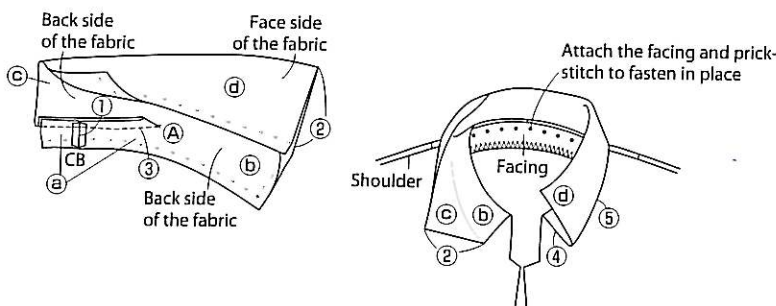
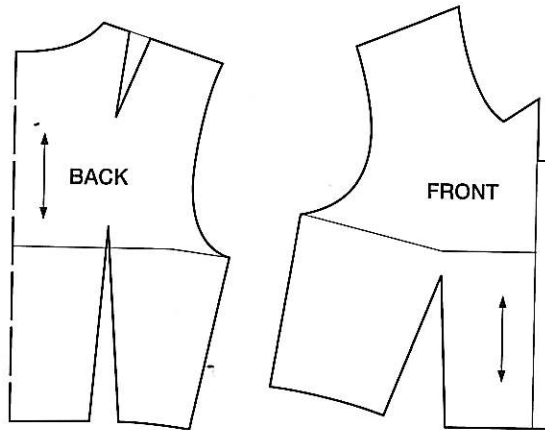

2 Align the shoulders of (a) and (b) and measure 4.5cm of collar width at a right angle from (A) on the collar attachment line for (b). Then connect from (b) and make a drawing for the front of (c) inside the collar. Because the back of the collar has a collar stand, measure the length of the back neckline and make a rectangular drawing.

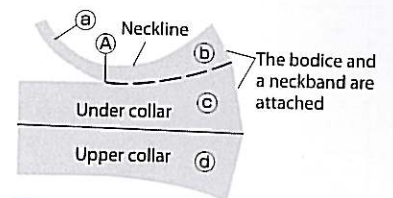

3 For a soft finish, cut the under and the upper collar continuously. Make the upper collar (d). (a), (b), (c) and (d) all interconnect to create a pattern where the bodice and the collar become one. Because (b) (the bodice) and (c) (the collar) are joined although the collar attachment line is curved, when you put it on, the collar floats upwards in the same way as the paper on the opposite page, for a completely different look.

Order for sewing together

- 1 Sew together the bodice (a) centre back.
- 2 Sew the collar edges for the collar patterns (c) and (d).
- 3 Sew the collar attachment line on the back bodice and (c).
- 4 Sew the front bodice and (b).
- 5 At the collar attachment line, sew (d) to the bodice.

* I have abbreviated the instructions, but when you actually construct the garment, attach the facing to the neckline of the bodice and prick-stitch to fasten the back collar attachment position and the facing-in place as shown in the drawing.

A method for making a full-size pattern from a half-scale pattern

The diagram below shows how to enlarge a part of the pattern for the *otoshiana* dress (page 19) to produce a full-size pattern.

① You will need some white paper on which to draw the half-scale and full-size patterns. Copy the half-scale muslin (toile) to make the paper pattern.

② Although you can start from anywhere, the method described here starts from ①.

From the line that directly ascends from ①, draw a line that hits ② at a right angle, and make the point where the two lines intersect into ③.

Double each of the two measurements \circ and σ , between ① and ② and between ② and ③ respectively, and copy onto the white paper.

④ Next take double the measurement of \square on the line that connects ① and ② in a straight line. From there, take double the measurement of \bullet at a right angle and draw a curve.

⑤ Extend the line from ③ to ④ by $\nabla \times 2$. Mark that point ⑥ and measure $\nabla \times 2$ at a right angle to meet ⑦.

⑥ Extend ⑦-⑧, take twice the measurement of Δ and mark ⑨. From ⑨, take twice the measurement of $\hat{\Delta}$ at a right angle and make it ⑩. Again take twice the measurement of \star and \blacktriangle at a right angle and make it ⑪.

Draw guide lines on the half-scale pattern and by doubling the guide lines, double the pattern lines and copy onto the white paper.

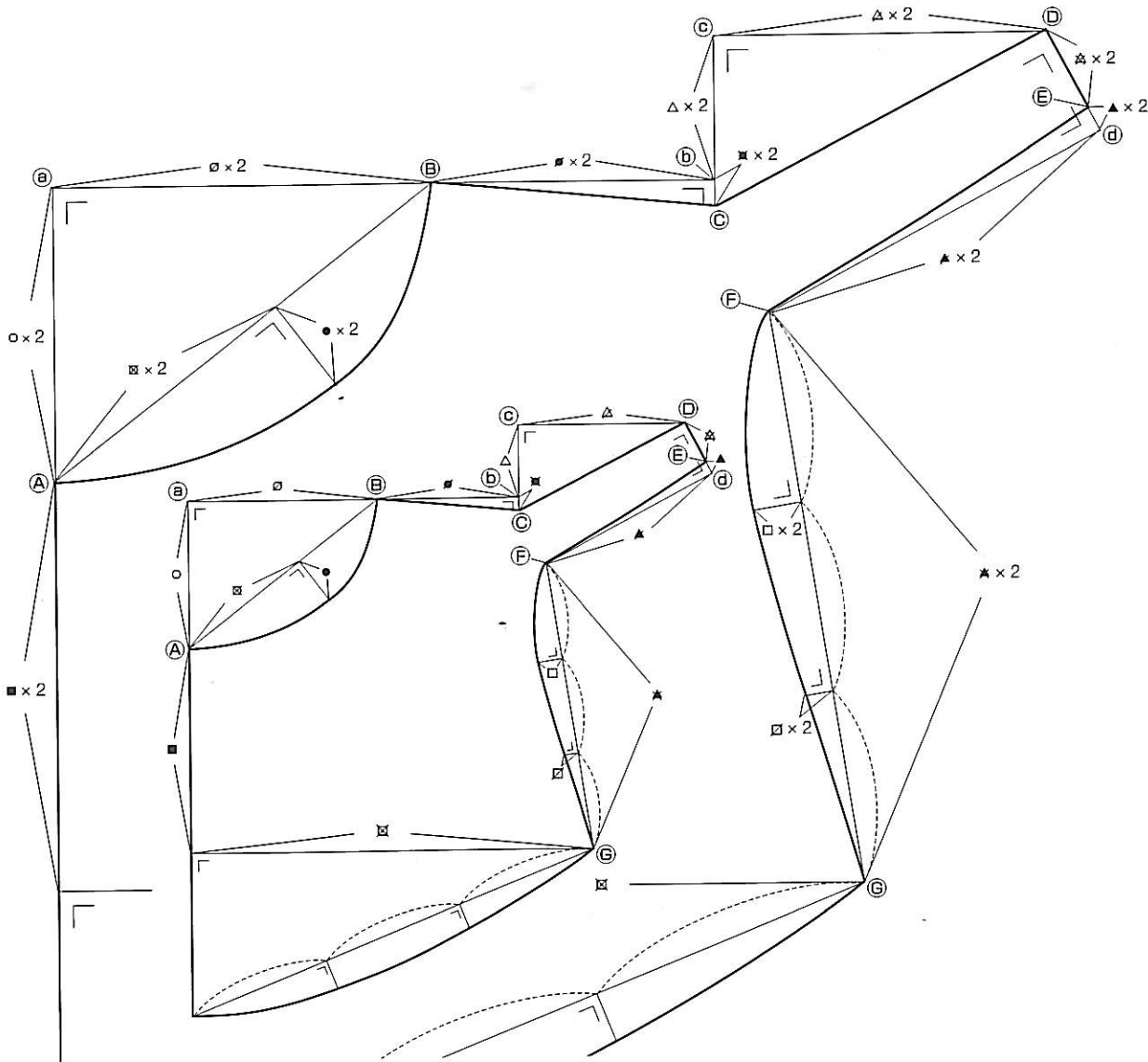

B	
77	
78	
79	
80	
81	
82	
83	
84	
85	
86	
87	
88	
89	

The basis for pattern development is the

Bunka-style sloper (block) for an adult woman

The Bunka-style sloper (block) created for the body shape of the modern Japanese woman is constructed three-dimensionally and fitted to the body with darts (bust darts, back shoulder darts, waist darts).

Bust (B), waist (W) and centre back length measurements are required to draw the sloper (block). The measurements for each part of the body are based on the bust measurement, and the size of each dart has been calculated from the bust and waist measurements. Each waist dart is calculated by the formula—bodice - (W/2 + 3)—where 3cm is the amount of ease added. Precise calculations are required for a neat fit, but drawings will be relatively easy if you refer to the quick reference table of measurements for different parts of the body. Pages 101 and 102 feature half-scale slopers (blocks) for you to use for each of the bust sizes: 77, 80, 83, 86 and 89cm.

Quick reference table of measurements for different parts of the body

(Unit: cm)

B	Body width	Ⓐ - BL	Back width	BL - Ⓑ	Chest width	$\frac{B}{32}$	Front neckline width	Front neckline depth	Bust darts	Back neckline width	Back shoulder darts
	$\frac{B}{2} + 6$	$\frac{B}{12} + 13.7$	$\frac{B}{8} + 7.4$	$\frac{B}{5} + 8.3$	$\frac{B}{8} + 6.2$	$\frac{B}{32}$	$\frac{B}{24} + 3.4 = \text{Ⓒ}$	Ⓒ + 0.5	$(\frac{B}{4} - 2.5)^\circ$	Ⓒ + 0.2	$\frac{B}{32} - 0.8$
77	44.5	20.1	17.0	23.7	15.8	2.4	6.6	7.1	16.8	6.8	1.6
78	45.0	20.2	17.2	23.9	16.0	2.4	6.7	7.2	17.0	6.9	1.6
79	45.5	20.3	17.3	24.1	16.1	2.5	6.7	7.2	17.3	6.9	1.7
80	46.0	20.4	17.4	24.3	16.2	2.5	6.7	7.2	17.5	6.9	1.7
81	46.5	20.5	17.5	24.5	16.3	2.5	6.8	7.3	17.8	7.0	1.7
82	47.0	20.5	17.7	24.7	16.5	2.6	6.8	7.3	18.0	7.0	1.8
83	47.5	20.6	17.8	24.9	16.6	2.6	6.9	7.4	18.3	7.1	1.8
84	48.0	20.7	17.9	25.1	16.7	2.6	6.9	7.4	18.5	7.1	1.8
85	48.5	20.8	18.0	25.3	16.8	2.7	6.9	7.4	18.8	7.1	1.9
86	49.0	20.9	18.2	25.5	17.0	2.7	7.0	7.5	19.0	7.2	1.9
87	49.5	21.0	18.3	25.7	17.1	2.7	7.0	7.5	19.3	7.2	1.9
88	50.0	21.0	18.4	25.9	17.2	2.8	7.1	7.6	19.5	7.3	2.0
89	50.5	21.1	18.5	26.1	17.3	2.8	7.1	7.6	19.8	7.3	2.0

Waist dart measurement—Quick reference table

(Unit: cm)

Total darts volume 100%	f	e	d	c	b	a
	7%	18%	35%	11%	15%	14%
9	0.6	1.6	3.1	1	1.4	1.3
10	0.7	1.8	3.5	1.1	1.5	1.4
11	0.8	2	3.9	1.2	1.6	1.5
12	0.8	2.2	4.2	1.3	1.8	1.7
12.5	0.9	2.3	4.3	1.3	1.9	1.8

Making a drawing of a sloper (block)

Slopers (blocks) are made for both the bodice and the sleeve, but only the method of drawing a bodice sloper (block), used throughout this book, is explained here.

Basic lines

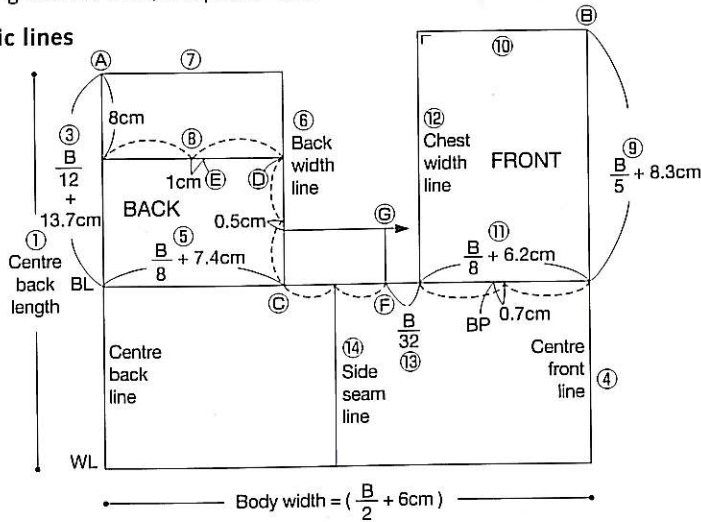

Firstly draw the basic lines for the bodice.

Accurately measure each part of the body and draw lines in the order of ① to ⑭. The numbers in the guide table are also arranged for reading in order from the left to help you proceed with pattern drafting in that order.

Curved lines

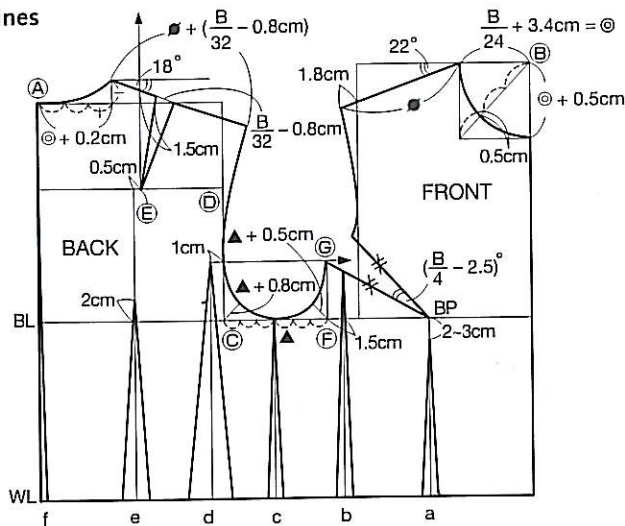

After drawing the basic lines, draw the curved lines of the neckline, shoulder, and armhole, and finally the darts.

Tips for moving darts

When you close the waist darts with ② as the pivotal point, the armhole opens a small amount to provide ease in the armhole. The waist darts on the sloper (block) are marked when used for pattern drafting but have been omitted where not required.

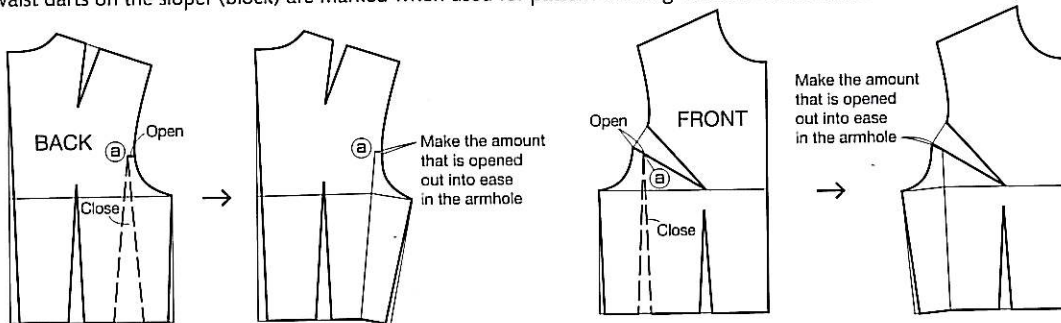

Bunka-style sloper (block) for an adult woman (Size M) (half-scale)

Copy at 200% on a photocopier to make the full-sized pattern.

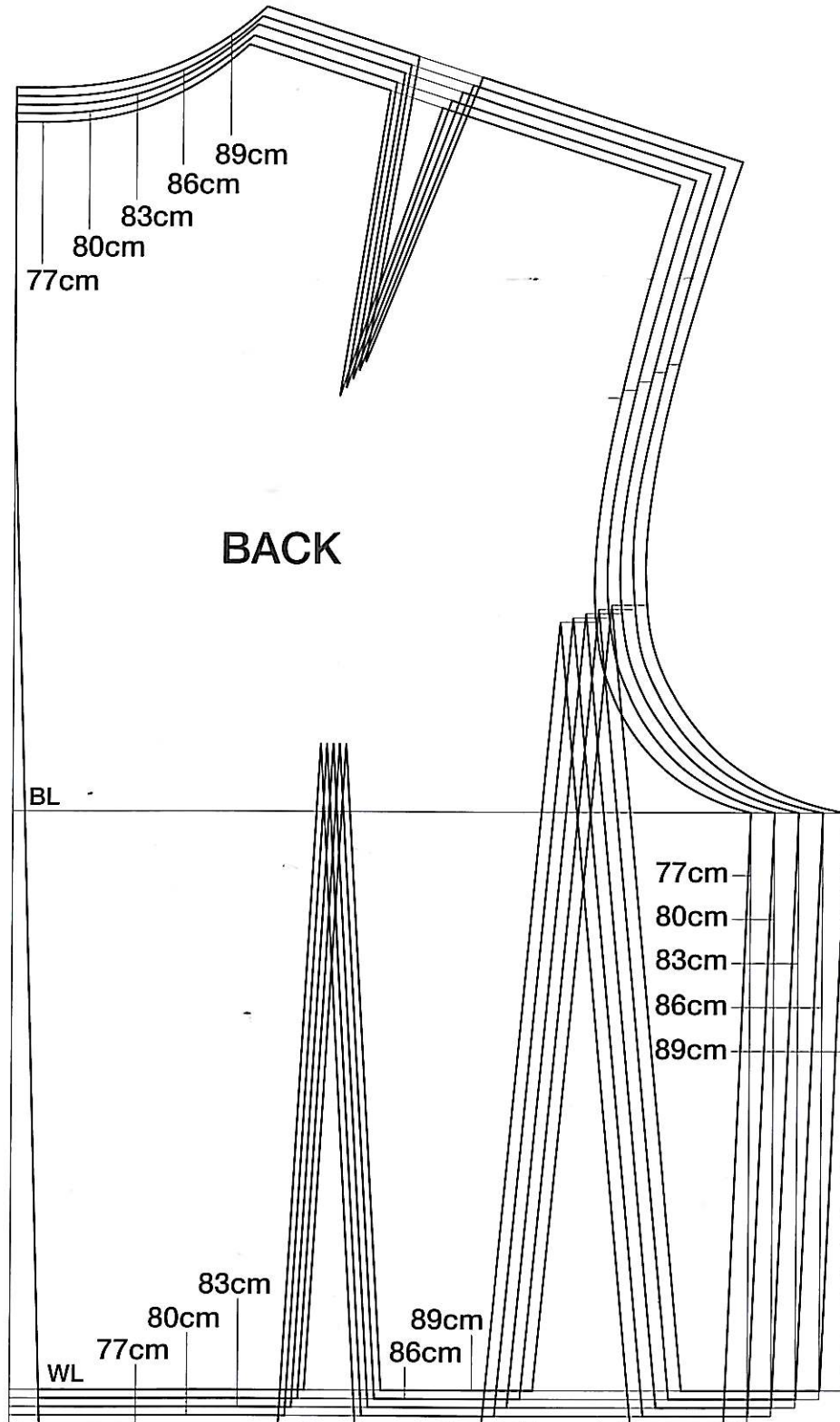

Bust (B)	Waist (W)	Back length
77cm	58cm	38cm
80cm	61cm	
83cm	64cm	
86cm	67cm	
89cm	70cm	

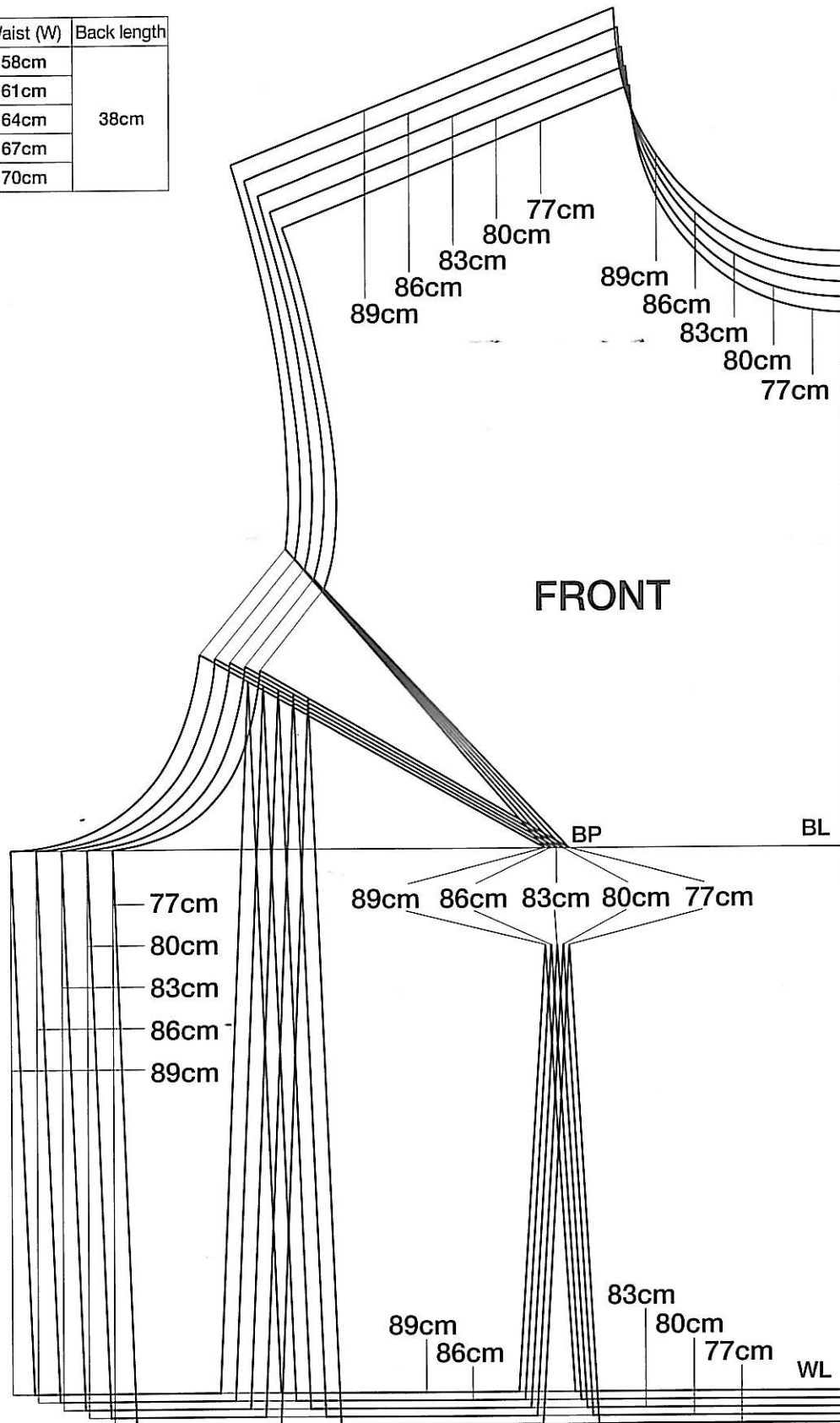

In conclusion

Just like works of art, garments come in various kinds: garments with visual impact, garments that react to the movement of the body, garments for casual wear—but there is no one prescribed way for how they are made. The history of clothing began with the wrapping of a piece of fabric around the body, so you should let your mind be free and approach the making of garments with a sense of fun. Ideas for garments are arguably infinite. I have always believed in experimenting with ideas. This book contains patterns that I have created based on a trial-and-error approach, and is supplementary to the teaching materials used at the Bunka Fashion Open College for students who may find pattern-making difficult.

I would like to express my appreciation to many people for their help in this publication, including Ms Kasai Fujino, from whom I received advice about slopers, and everyone who has shown an interest in this book.

PATTERN MAGIC

Tomoko Nakamichi

Available for the first time in English, *Pattern Magic* is the cult pattern-making book from Japan. Step-by-step projects show you how to create stunning, sculptural clothes, using a creative approach to pattern making.

All the information you need to start pattern making is included, from the basic sloper to measurements and scaling. Each project is beautifully illustrated with clear diagrams and photographs showing the stages of construction, the muslins, and the finished garments.

With 200 color illustrations

"This book is fabulous. The English language edition makes the techniques accessible to the novice and students alike. My students will now be able to incorporate the ideas into their coursework with ease."

Mary Gottlieb, Parsons, The New School for Design.



\$24.95

Having served many years as a professor at Bunka Fashion College, Tomoko Nakamichi currently delivers lectures and holds courses on pattern making, in her native Japan and internationally. This book brings together the results of the research on garment patterns she has carried out to help instruct her students.

For more information, or to order, go to
www.laurenceking.com

For our current catalog please email
sales@laurenceking.com